

AUTOMATIC AIR VALVES

For potable water



Page
N 2

Air release valve

DN 1" und DN 2", PN 6, PN 16

Page N 2/1



Page
N 3

Air release valve HaVent

PN 25

Page N 3/1



Page
N 4

Air release valve

DN 80 / DN 100, DN 150 / DN 200

Page N 4/1



Page
N 5

Combined air release valve

Page N 5/1



Page
N 6

Air release valve

Dynamic PN 10 | PN 16 | PN 25 | PN 40

Page N 6/1



Accessories

Flushing stand pipe Page N 5/1
Surface box Page M 3/3

Spare parts

Valve 1" Seite N 2/2

Tools

Valve key 1" Page Q 4/2

Dimensioning (recommendation)

Pipe	Valve
DN ≤ 80	DN 1"
DN 100 - 250	DN 2" (DN 50)
DN 300 - 400	DN 80
DN 450 - 500	DN 100
DN 600 - 900	DN 150
DN ≥ 1000	DN 200

Technical information

Tightening torques for flange assembly Page R 3/1

Application examples



AIR RELEASE VALVES

PN 6 | PN 16



Design features

- Automatic, dynamic air release valve
- PE shield for UV protection
- The internal thread inlet is reinforced with a stainless steel ring
- Connection variants: Internal thread or flange
- Insect protective grid (2" valve)
- Installation: upright, preferably at the highest point in the pipeline together with isolating valves
- Air valve for releasing air only: on request (minimum pressure of 0,3 bar needed)

Material | Technical features

- **DN 1"**
 - Max. air release capacity:** 0,13 m³/min.
 - Test pressure:** Body 24 bar
 - Working pressure:** 0,1 - 6 bar
0,8 - 16 bar
 - **Body** made of POM
 - **Orifice and valve plug** made of brass
 - **Float** made of POM
 - **Seal** made of Elastomer
 - **UV-shield** made of PE
- **DN 2"** - double acting
 - Max. air release capacity:** 3,2 m³/min.
 - Test pressure:** Body 24 bar
 - Working pressure:** 0,1 - 6 bar
1 - 16 bar
 - **Body and elbow** made of POM
 - **Valve seat** made of brass
 - **Float** made of POM
 - **Seal** made of Elastomer
 - **UV-shield** made of PE
 - **Insect protective grid** made of stainless steel

No. 9876 DN 1"



No. 9876 DN 2"



No. 9874 DN 2"

Order No.	Version	DN	Working pressure bar
9876	Standard	1"	PN 0,1 - PN 6
			PN 0,8 - PN 16
9876	Standard	2"	PN 0,1 - PN 6
			PN 1 - PN 16
9874	With flange connection DN 50 or DN 80 (ductile iron)	2"	PN 0,1 - PN 6
			PN 1 - PN 16

Automatic air valves are to be maintained according to the usage conditions

AIR RELEASE VALVES

PN 6 | PN 16



DN	MOP (PN)	Working pressure bar	Size of the opening	Ø D	Ø D1	H	Weight
1"	6	0,1 - 6	1,77 mm ²	109	122	172	0,90
	16	0,8 - 16					

Please specify working pressure when ordering

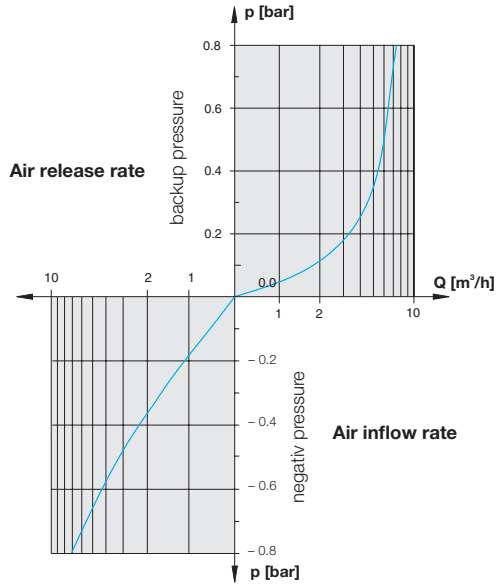

No. 9876 DN 1"

Valve (= wearing part)

No: QA00001600Q013 PN 16
No: QA20001600Q013 PN 6

Replaceable on the spot in depressurised status

- Demount safeguard ring
- Remove cap
- Loosen locking screw
- Valve with valve key unscrew No. 3454

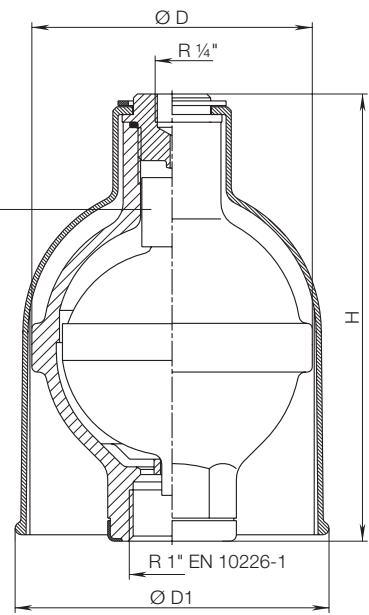

DN	MOP (PN)	Working pressure bar	Size of the opening	Ø A	Ø A1	H	H1	Weight
2"	6	0,1 - 6	900/2 mm ²	160	175	305	320	2,90
	16	1 - 16						3,40

Please specify working pressure when ordering

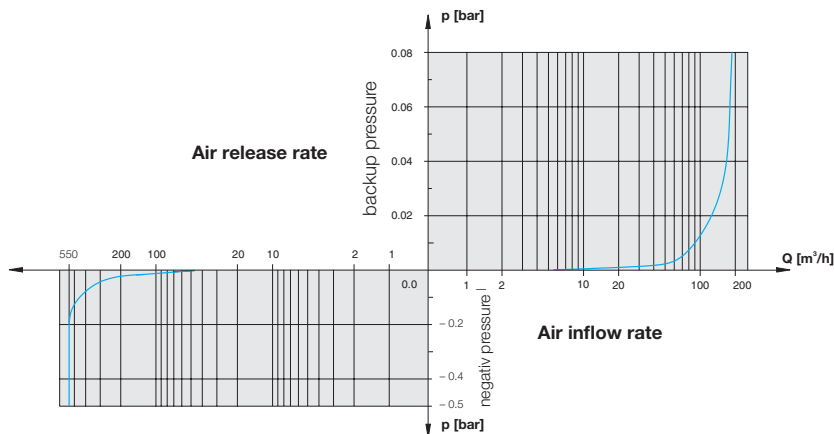

No. 9876 DN 2"

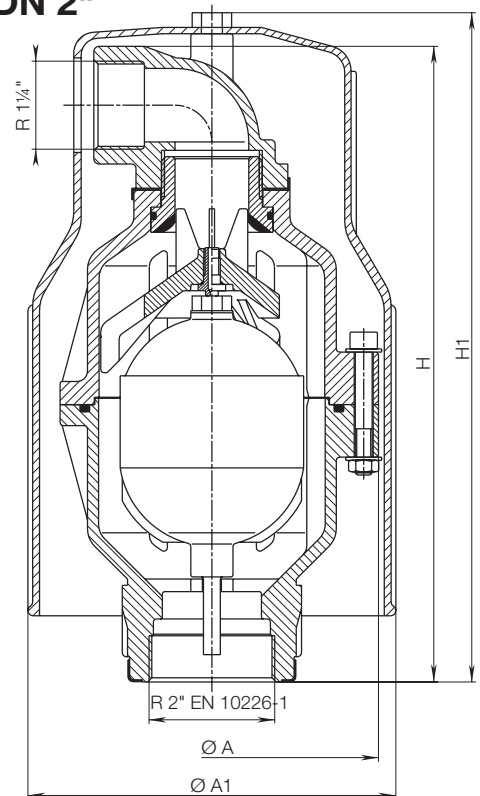

AIR RELEASE VALVES HaVent

PN 25



Design features

- High performance air release valve with new nozzle mechanism for the optimal absorption of high pressures
- Low wear and tear due to optimum geometry
- Easy maintenance
- High-quality materials
- UV resistance
- Air release only on request
- Connecting variants: Flange DN 50, DN 80, internal thread 2"
- With insect protective grid

Material | Technical features

- **Size of the opening:** 1500 mm³ / 3,15 mm²
- **Max. air release capacity:** 700 m³/h
- **Working pressure:** 0,2 - 25 bar
- **Body** made of stainless steel
- **Float** made of foamed PP
- **Seal** made of Elastomer
- **Outlet elbow** made of PE
- **Flange** acc. EN 1092

No. 9859



Connection	H	Ø D	Weight	
IG 2"	420	160	10,00	
Flange DN 50*	455	160	12,50	
Flange DN 80*	455	160	14,50	

*on request

AIR RELEASE VALVES HaVent

PN 25



Air release capacity when filling the pipeline

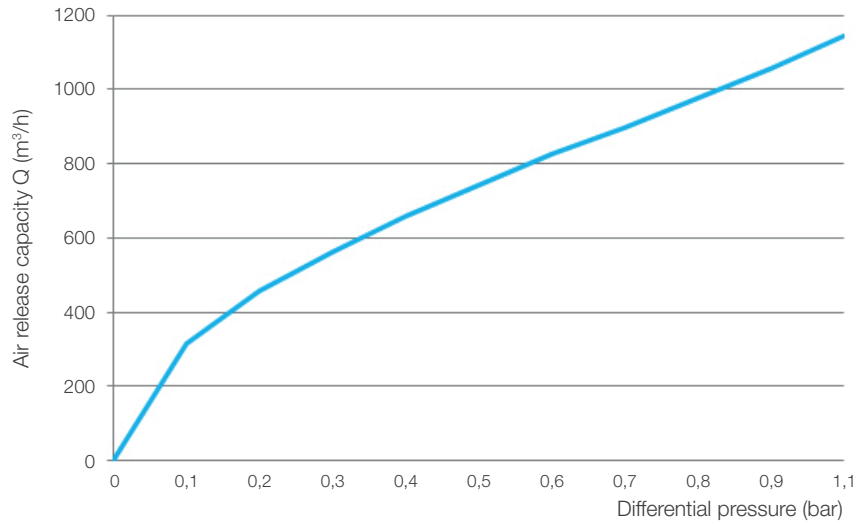

Working air release

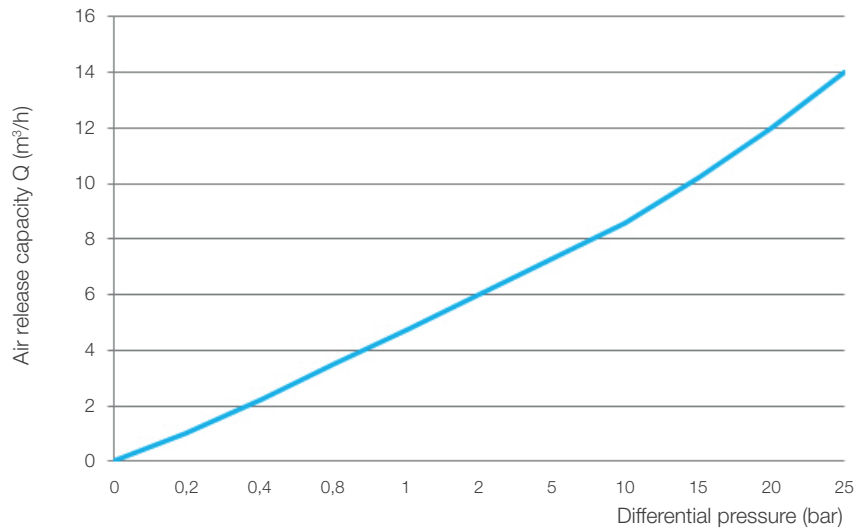

Aeration the pipeline

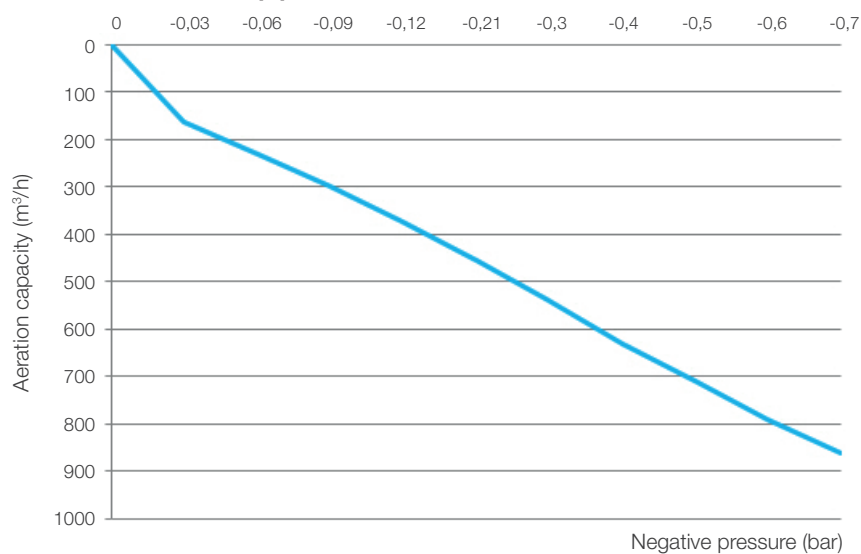

AIR RELEASE VALVES

PN 6 | PN 16



Design features

- Automatic air release valve
- All mechanical parts made of corrosion resistant materials

Material | technical features

- **Body and bonnet** made of ductile cast iron, epoxy powder coated
- **Seat** made of brass / elastomer
- **Float:** DN 80-100 polycarbonate
DN 150-200 passivated stainless steel
- **Double nipple** made of POM / stainless steel
- **Bolts and nuts** made of stainless steel

No. 9835 DN 80 / DN 100

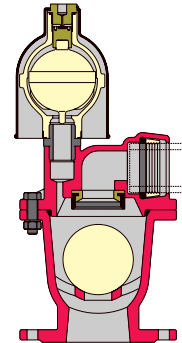

DN 150 / DN 200

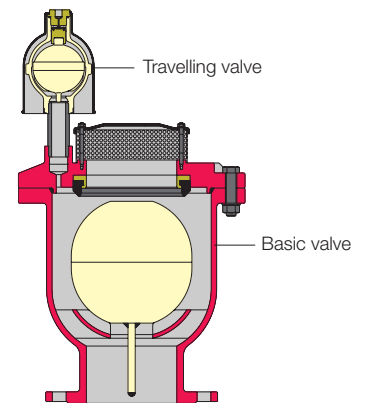

Dimensions	DN 80	DN 100	DN 150	DN 200*
Test pressure (body)	24 bar			
Working pressure PN 16 (standard)	0,8 - 16 bar			
Working pressure PN 6	0,2 - 6 bar			
Max. air release capacity	1305 m³/h	2450 m³/h	7500 m³/h	
Size of the opening	1810/1,77 mm²	3320/1,77 mm²	17670/1,77 mm²	
PE pipe connection	d 63	d 75		
Flange drilled acc. EN 1092-2 PN 10; *DN 200 PN 16 EN 1092-2 please specify on order				

Order No.	Version	Working pressure bar	DN 80	DN 100	DN 150	DN 200
9835	Double orifice (with travelling valve)	PN 6 (0,2 - 6 bar)				
		PN 16 (0,8 - 16 bar)				
9836	Double orifice, (with travelling valve) with PE pipe & insect protective grid	PN 6 (0,2 - 6 bar)				
		PN 16 (0,8 - 16 bar)				
9837	Single orifice (without travelling valve)	PN 16 (0,2 - 16 bar)				
9838	Single orifice (without travelling valve) with PE pipe & insect protective grid	PN 16 (0,2 - 16 bar)				

AIR RELEASE VALVES

PN 6 | PN 16



DN 80 / DN 100

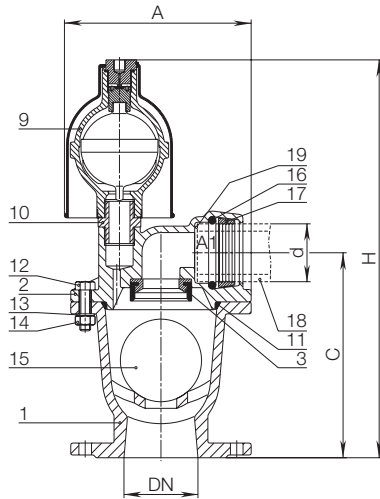

DN 150 / DN 200

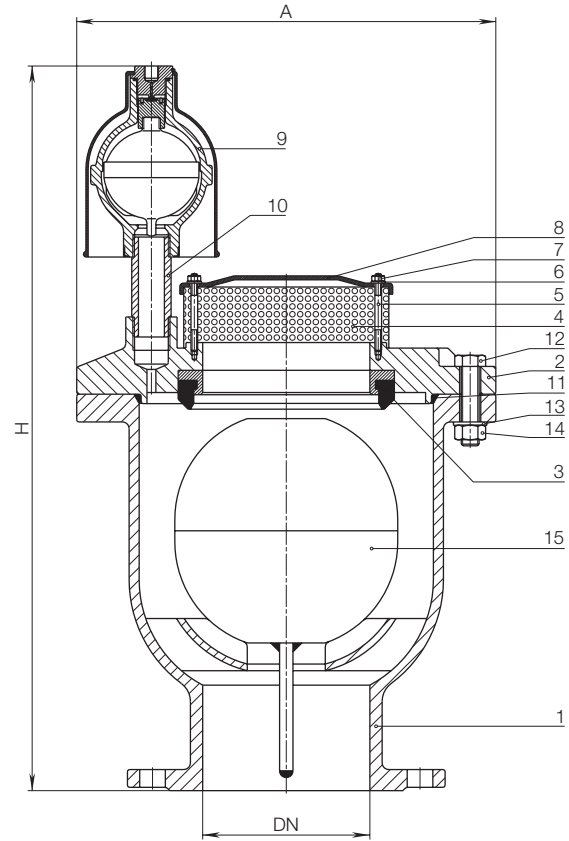

Parts	Material
1,2 Body and bonnet	Ductile cast iron, epoxy powder coated
3 Seat	Brass / Elastomer
4 Grid	Stainless steel
5 Bolt	Stainless steel
6 Washer	Stainless steel
7 Nut	Stainless steel
8 Cap	Steel, epoxy powder coated
9 Automatic air valve 1"	Divers (see page N 2/1)
10 Nipple	POM (DN 80-100) / NIRO (DN 150-200)
11 O-ring	Elastomer
12 Hexagonal bolt	Stainless steel
13 Washer	Stainless steel
14 Hexagonal nut	Stainless steel
15 Float	DN 80 - 100 Polycarbonat DN 150 - 200 Passivated stainless steel
16 O-ring	Elastomer
17 Clamp ring	POM
18 Pipe tail (on request)	PE
19 Insect protective grid (on request)	Stainless steel

DN	A	H	C	d	Weight
80	212	455	230	63	17,0
100	250	505	260	75	25,0
150	387	686			75,0
200	387	686			81,0

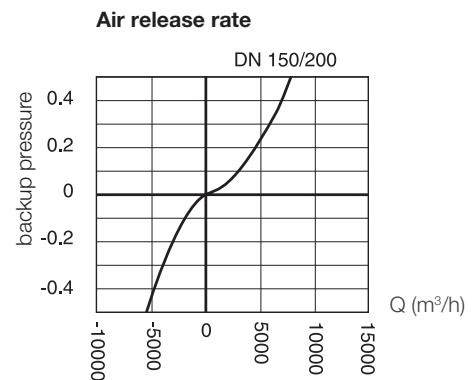
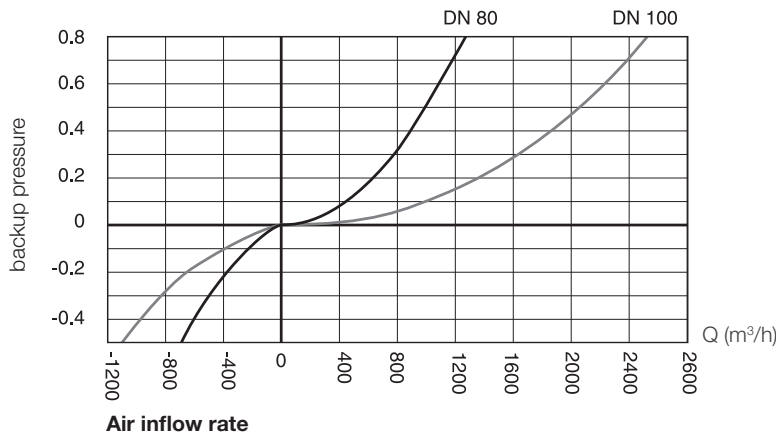

COMBINED AIR RELEASE VALVES



Design features

- This arrangement eliminates expensive valve chambers
- The stand pipe protects the automatic air valve
- An automatic shut-off valve enables the equipment to be easily removed for inspection and reinstalled under pressure
- The materials used for the air release valve guarantee absolute corrosion resistance
- Excess water is drained away through an DN 1/2" ISO-pipe-fitting
- For below-ground installation a surface box with minimum opening of 300 mm diameter is required. Gravel backfilling should be used to prevent rain water from accumulating in the surface box (see Illu. 2 page N 5/2)
- The air release valve can be shortened by 100 mm by cutting the standpipe 5 and extension pipe 3 at the red marks
- Valve only for air release: on request (minimum pressure of 0,3 bar needed)

No. 9822
No. 9823



**Air valve for releasing air only:
(with air inflow stop) on request**
(see over page illu. 3)

Material | Technical features

- **Standpipe** made of stainless steel
- **Air release valve** made of POM and brass
- **Max. air release capacity:** 3,2 m³/min
- **Inlet flange:** DN 50 or DN 80 sized and drilled according to EN 1092-2 | PN 16

Suitable accessories

- Surface box No. 1790
- **Flushing stand pipe** including shut-off valve; Instead of the air valve assembly a stand pipe can be supplied for water main flushing and for general water discharge

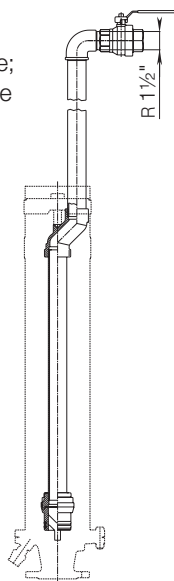

Order No.	L	Weight
9824	755	4,70
	1055	5,80
	1305	6,75
	1555	9,50

L = Total length of the combined air release valve

Order No.	Working pressure bar	DN	Installation depth		L*	Weight
			Above ground (Illu.1)	Below-ground (Illu.2)		
9822	PN 1 - PN 16	50	0,75 m	1,00 m	755	22,0
			1,00 m	1,25 m	1055	25,5
			1,25 m	1,50 m	1305	29,0
			1,50 m		1555	33,5
		80	0,75 m	1,00 m	755	23,5
			1,00 m	1,25 m	1055	27,0
			1,25 m	1,50 m	1305	30,0
			1,50 m		1555	31,0
9823	PN 0,1 - PN 6	50	0,75 m	1,00 m	755	22,0
			1,00 m	1,25 m	1055	25,5
			1,25 m	1,50 m	1305	30,0
			1,50 m		1555	33,0
		80	0,75 m	1,00 m	755	24,0
			1,00 m	1,25 m	1055	28,0
			1,25 m	1,50 m	1305	30,0
			1,50 m		1555	33,0

*L = 100 reducible

Minimum length = 650
Maximum length = 2500

PN 25 on request

Application example

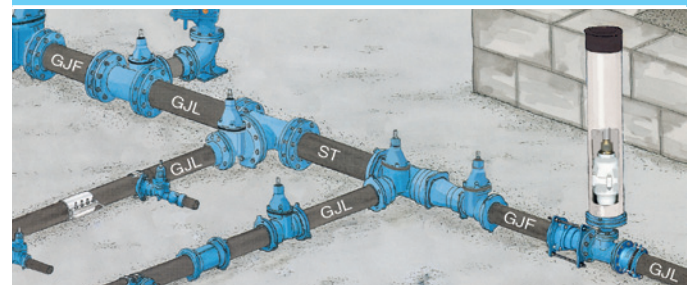

COMBINED AIR RELEASE VALVES



Illu. 1

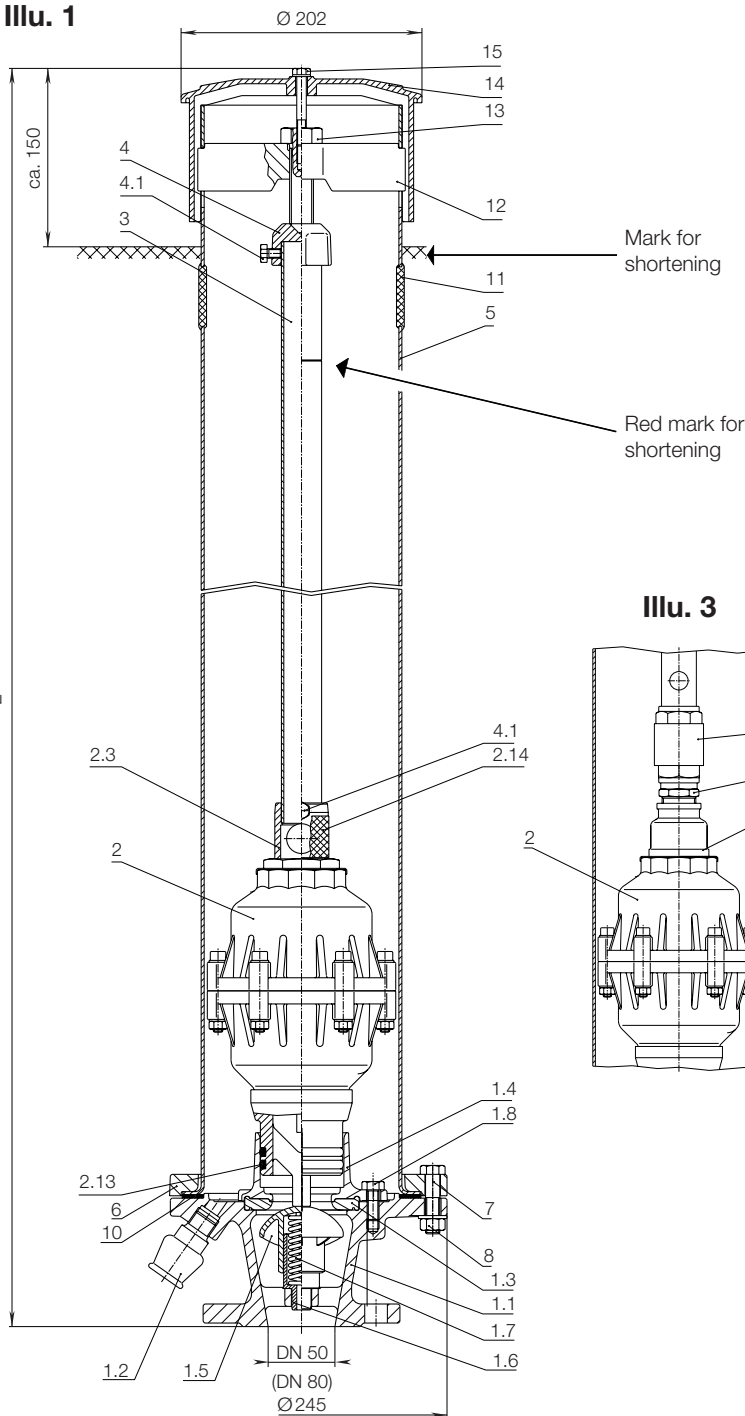

Illu. 2

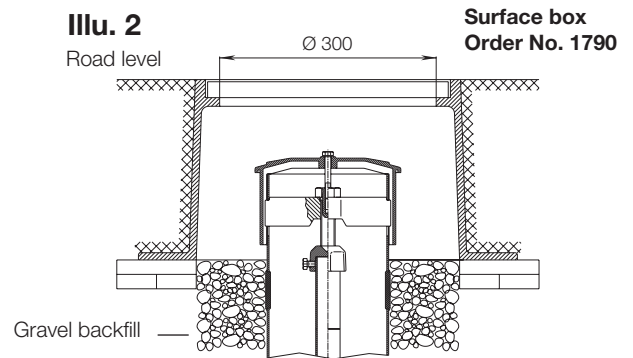

Illu. 3

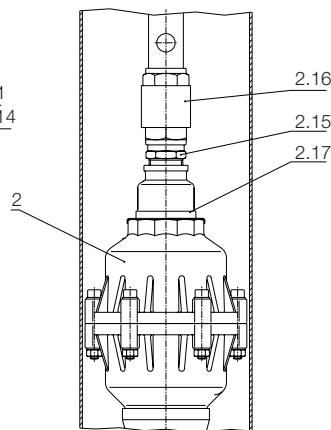

	Parts	Material
1.1	Inlet flange	Ductile iron
1.2	Drain-off fitting	Ductile iron
1.3	Seal	Elastomer
1.4	Foot valve flange	Brass
1.5	Foot valve	POM
1.6	Spring case	POM
1.7	Spring	Stainless steel
1.8	Hexagon bolt M 10	Stainless steel
2	Air valve	see page N 2/1
2.3	Seat	Brass/Elastomer
2.13	O-ring	Elastomer
2.14	Insect protective grid	Stainless steel
2.15	Double nipple	Brass
2.16	Non return valve	Brass
2.17	Reducing socket	Brass
3	Pipe	Stainless steel
4	Coupling	Ductile iron
4.1	Hexagon bolt	Stainless steel
5	Stand pipe	Stainless steel
6	Lock ring	Ductile iron
7	Hexagon bolt M 12 x 55	Stainless steel
8	Hexagon nut	Stainless steel
10	Seal	Elastomer
11	Blind cover	Elastomer
12	Spindle support	
13	Operating bolt	Stainless steel
14	Hood	HDPE
15	Hexagon bolt	Stainless steel

AIR RELEASE VALVES

Dynamic PN 10 | PN 16 | PN 25 | PN 40



Design features

- Automatic 3-way air release valve with cylindrical floats
- Ventilation outlet in nominal size (large opening cross-section according to the flange size)
- Flange pursuant to EN 1092-2 (DN 50 can also be shipped with threaded connection 2")
- Efficient, high performance ventilation protects pipeline from vacuum related damages
- High velocity air discharge prevents premature closure, thus safeguarding optimum ventilation during filling process of pipe lines or containers
- 2-level ventilation system provides effective protection against pressure shocks during high ventilation speeds through a small opening
- Continuously reliable ventilation of air inlets under normal operating conditions
- Compact construction, low volume and weight
- Robust and reliable technology

Material | Technical features

- **Body** made of ductile iron, epoxy powder coated inside and outside (see page 4)
- **Sealing rings** made of elastomer
- **All other metallic parts** made of stainless steel
- **Float material** made of PE
- **Medium:** water

Functional principle

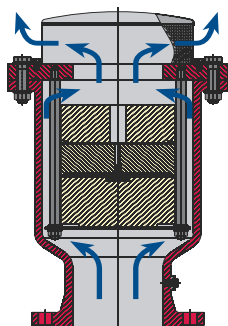

Ventilation of large quantities of air:
During filling, the line will be ventilated via the large cross-section

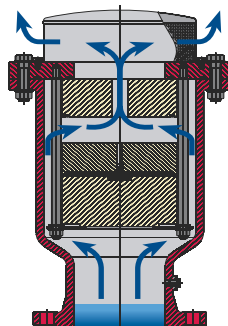

Ventilation at high air velocity through small opening: Prevention of pressure shocks or premature closure

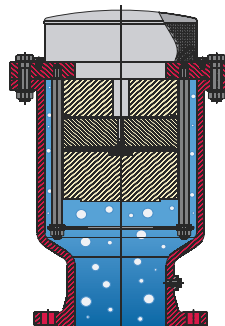

Closure:
After ventilation the valve closes automatically

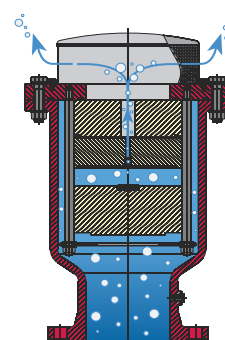

Ventilation of small quantities of air:
During operation of a line, ventilation is carried out via the small cross-section

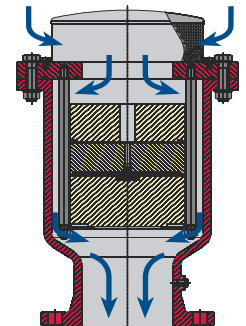

Ventilation:
During drainage of a line, ventilation is carried out via the large cross-section.

No. 9842K



Order No.	MOP (PN)	Dimension/DN						
		50	80	100	150	200	250	300
9842K	10							
	16							
	25							
	40							

* Other dimensions or pressure rating on request

Application example

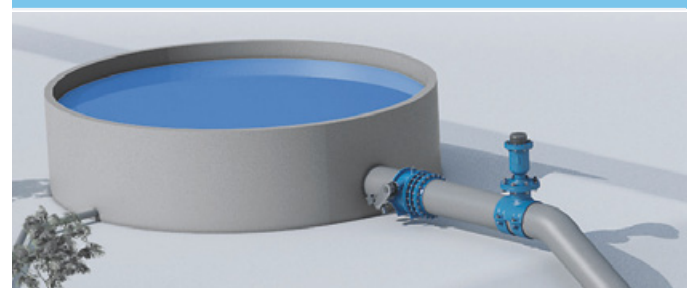

AIR RELEASE VALVES

Dynamic PN 10 | PN 16 | PN 25 | PN 40



No. 9842K

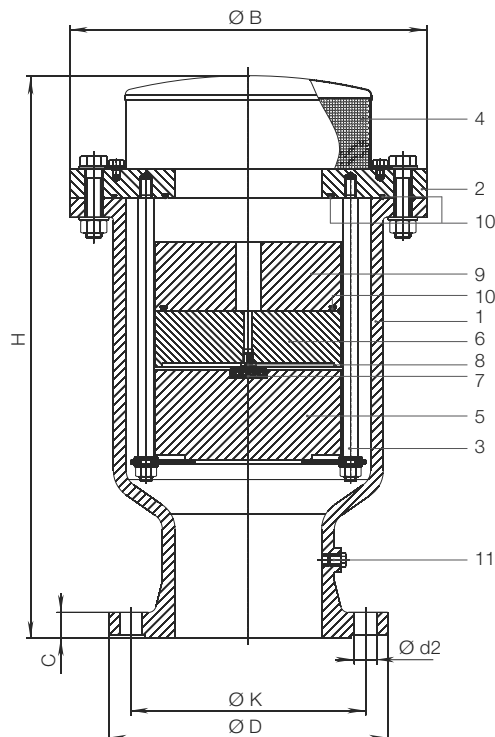

	Parts	Material
1	Body	Ductile iron
2	Bonnet	Steel (stainless steel optional)
3	Float guide	Stainless steel
4	Cover	Stainless steel
5	Float	PE
6	Float	PE
7	Sealing seat	Elastomer
8	Small opening	Stainless steel
9	Float	PE
10	O-ring	Elastomer
11	Plug	Steel

DN	MOP (PN)	Ø D	Ø K	C	Bolts		Ø B	H	Weight
					Quantity	Ø d2			
50	10/16	165	125	19	4	19	200	355	20
80		200	160	19	8	19	240	420	26
100		220	180	19	8	19	255	420	28
150		285	240	19	8	23	365	580	90
200	10	340	295	20	8	23	410	630	98
200	16	340	295	20	12	23	410	630	98
250	10	405	355	22	12	23	540	820	160
250	16	405	355	22	12	28	540	820	160
300	16	460	410	24,5	12	28	650	927	180

DN	MOP (PN)	Ø D	Ø K	C	Bolts		Ø B	H	Weight
					Quantity	Ø d2			
50	25	165	125	19	4	19	200	355	22
80		200	160	19	8	19	240	420	28
100		235	190	19	8	23	255	420	30
150		300	250	20	8	28	365	580	95

DN	MOP (PN)	Ø D	Ø K	C	Bolts		Ø B	H	Weight
					Quantity	Ø d2			
100	40	235	190	19	8	23	255	420	30