

# H4000

## Woltmann cold water meters

## Product specification



### H4000 performance (forward flow)

Meter size (mm)			40	50	65	80	100	125	150	200	250	300
Overload flow	qs±2%	m³/h	90	90	120	200	250	250	600	1000	1600	2000
Permanent flow	qp±2%	m³/h	50	50	65	120	180	180	450	700	1000	1500
Transitional flow	qt±2%	m³/h	1	1	1.5	2	2	2	4	6	11	15
Minimum flow (horizontal)	qmin±5%	m³/h	0.35	0.35	0.4	0.5	0.6	0.6	1.8	4	6	12
Minimum flow (vertical)	qmin±5%	m³/h	0.45	0.45	0.75	1.2	1.2	1.2	4.5	7.5	12	18
Starting flow (approximately)		m³/h	0.15	0.16	0.17	0.22	0.25	0.25	0.90	1.2	1.8	1.8
Headloss at maximum flow		bar	0.84	0.49	0.69	0.27	0.43	0.58	0.33	0.32	0.37	0.58
Maximum registration		millions of m³	1	1	1	1	1	1	10	10	10	10
Maximum water temperature		°C	50	50	50	50	50	50	50	50	50	50
Maximum working pressure		bar	16	16	16	16	16	16	16	16	16	16

### Standard ISO4064/BS5728/EEC specification Class B

Overload flow	qs±2%	m³/h	-	30	50	80	120	200	300	500	800	1200
Permanent flow	qp±2%	m³/h	-	15	25	40	60	100	150	250	400	600
Transitional flow	qt±2%	m³/h	-	3	5	8	12	20	30	50	80	120
Minimum flow	qmin±5%	m³/h	-	0.45	0.75	1.2	1.8	3	4.5	7.5	12	18
Headloss at maximum flow		bar	-	0.05	0.12	0.04	0.10	0.37	0.10	0.10	0.09	0.21
Headloss class		bar	-	0.10	0.30	0.10	0.10	0.60	0.10	0.10	0.10	0.30

### Dimensions

Meter size (mm)			40	50	65	80	100	125	150	200	250	300
Overall length (ISO) (A)		mm	300	200/300	200/300	200/350	250/350	250	300/500	350	450	500
Overall length (Kent) (A)		mm	311	311	-	413	483	-	-	520	-	-
Height (B)		mm	78	78	86	94	106	118	135	165	198	225
Height (D)		mm	148	148	148	159	159	159	206	228	246	246
Height (E)		mm	236	236	236	247	247	247	294	316	334	334
Flange diameter (C)		mm	151	166	186	201	228	251	286	341	409	461
Weight (ISO)		kg	11.8	12.2/13.1	13/14.4	14.1/16.6	19.4/21	20.5	37.5/43.5	47.5	82	104
Weight (Kent)		kg	12	13.3	-	17.6	23.6	-	-	54	-	-

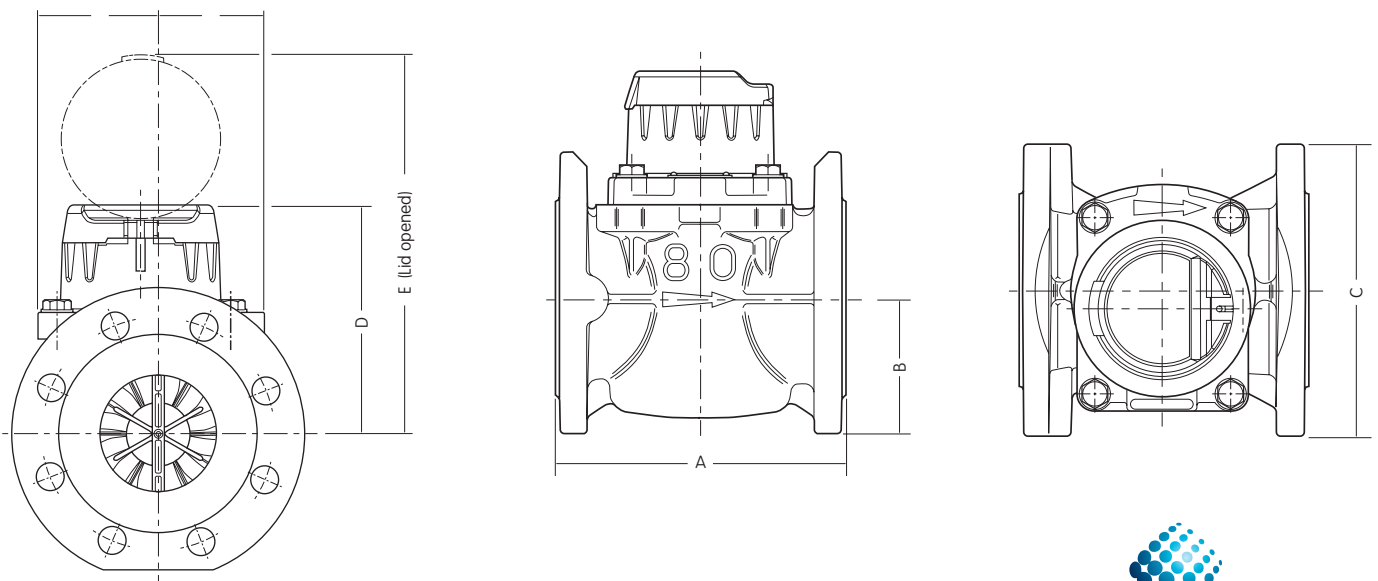

Accuracy curve, headloss curve and pulse connectivity shown overleaf.

# H4000

## Woltmann cold water meters

## Product specification



### Typical accuracy curve

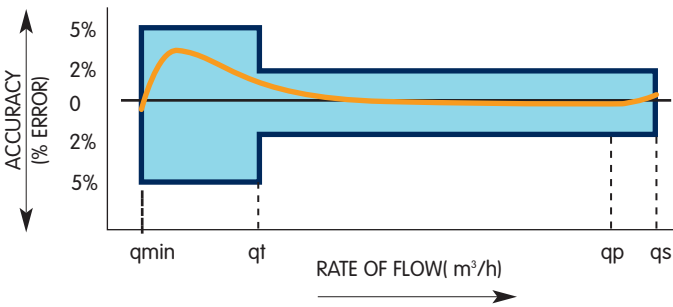

### Typical headloss curve

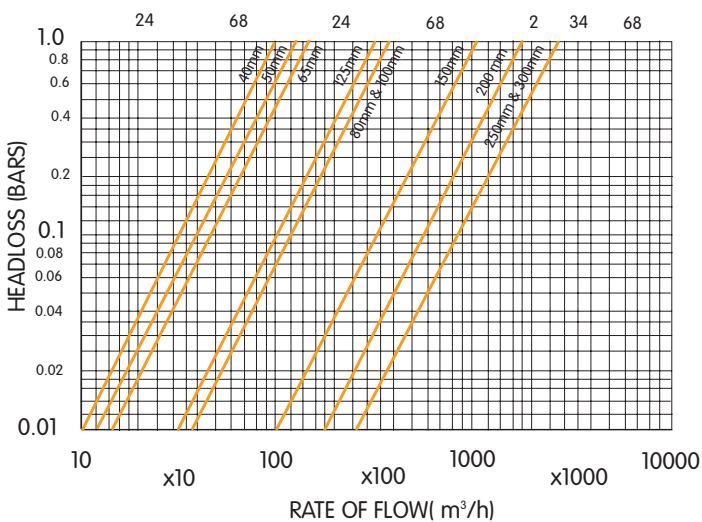

### Pulse connectivity

Calculating pulse weights when fitted with PR7 inductive pulser:

Pulse weight is calculated by multiplying the register 'pulse factor' (P) by the

PR7 'K-factor' (K);

Pulse weight (litres per pulse) =  $P \times K$ .

Size	Pulse factor	K-factor			
		K1	K10	K100	K1000
40mm	P:1	1 ltr	10 ltrs	100 ltrs	1,000 ltrs
50mm	P:1	1 ltr	10 ltrs	100 ltrs	1,000 ltrs
65mm	P:1	1 ltr	10 ltrs	100 ltrs	1,000 ltrs
80mm	P:1	1 ltr	10 ltrs	100 ltrs	1,000 ltrs
100mm	P:1	1 ltr	10 ltrs	100 ltrs	1,000 ltrs
125mm	P:1	1 ltr	10 ltrs	100 ltrs	1,000 ltrs
150mm	P:10	10 ltrs	100 ltrs	1,000 ltrs	10,000 ltrs
200mm	P:10	10 ltrs	100 ltrs	1,000 ltrs	10,000 ltrs
250mm	P:10	10 ltrs	100 ltrs	1,000 ltrs	10,000 ltrs
300mm	P:10	10 ltrs	100 ltrs	1,000 ltrs	10,000 ltrs

PR7 is an open collector pulse transmitter suitable for data logging, AMR and telemetry equipment. Check with your equipment supplier for full details of compatibility.

Pressure equipment directive 97/23/EC. This product is applicable in networks for the supply, distribution and discharge of water and associated equipment and is therefore exempt.



- On this example 50mm H4000 register, the user can identify from the dial plate both the:
  - Type of pulser to use, i.e. PR7
  - Pulse factor, i.e. P:1



- On the PR7 unit the user can identify from the label the K-Factors for each output channel
- Primary output K-factor
- Secondary output K-factor