

## Intelligent Foundation Solutions

RETENTION SYSTEM™ sockets are intelligent foundation solutions for the installation and maintenance of posts.

Essential to sustainable infrastructure design, they add value through improved asset management and performance, reduced operational costs and deliver environmental, health and safety benefits.



### world leading design...

- Patented design tested to international standards
- Approved and used throughout the world
- High-strength, reusable design survives vehicle impact
- Solution for knock-down and access-control locations
- Eliminates repeat excavation, disruption and expense
- Shallow foundation options for congested sites
- Easy to handle, adjust and install on site
- Facilitates electrical cabling at ground level
- Simplifies project, contractor & site management
- Assists maintenance and seasonal schedules
- Supports health and safety work practices
- Promotes environmental policies and targets

### Sustainable Infrastructure Design



## RSe245

RSe245 socket for the installation of Ø245mm (9.8in) posts including CCTV posts, signs, lighting columns...

# RETENTION SYSTEM™

sockets for post installation



RS sockets are available in common industry sizes and post installation depths. Base options include: standard [flat] / duck-foot & tee bends for cable access / shallow foundation. RS engineered sockets are made to size, specification and installation requirements.

[www.retention-system.com](http://www.retention-system.com)

- » Facilitates Passive Safety design to EN12767
- » Foundation size and specification to EN40 & BD94/07
- » Product tested and load rated to EN124 B125

RETENTION SYSTEM™ is a trademark and patented product of IPL group | Innovative Products Ltd:  
ISO 9001 / ISO 14001 / OHSAS 18001

IPL group | +353 (0) 41 983 2591



## RS socket installation & specification...

The **RS socket** should be set into concrete generally in accordance with International Standards or good Codes of Practice for the installation of posts.

1. Prepare hole at least 75mm deeper than the overall height of the **RS socket**. If depth for **RS socket** cannot be achieved, unit can be shortened on site. Please contact your supplier for technical support.
2. Compact at least 75mm of MOT type 1 granular material in base of hole.
3. Position **RS socket** in centre of hole. For cabled installations connect ducting from remote chamber to swivel bend on socket. Leave draw cord in base of **RS socket** bend.
4. Rotate the **RS socket** head into the required orientation.
5. Remove locking lid, loosen the one M24 locking set-screw and remove the pedestrian plug.
6. Install a levelling post (stump pole) in the **RS socket**, fasten the locking set-screw and replace the locking chamber lid.
7. Surround with the required amount of concrete (ST4 mix or stronger). Use stump pole to achieve a vertical level.
8. Once vertical level is achieved, compact concrete.
9. Once concrete has been compacted and has begun to cure, carefully remove stump pole and lock the pedestrian plug in place.
10. Replace the locking chamber lid and secure in position. Finish footway with required surface when concrete has cured.

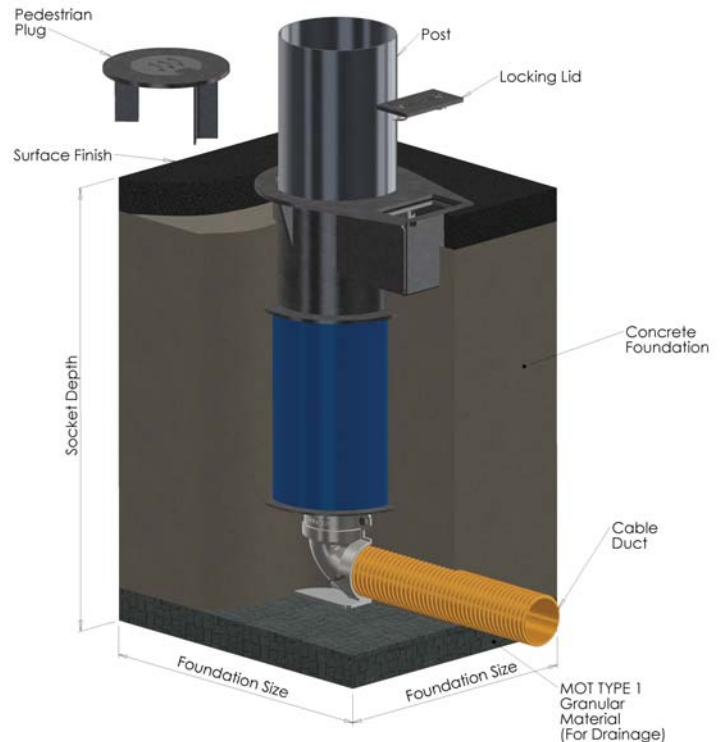

See **RS socket** installation guide for EN40-3-1:2000 foundation guidelines  
For detailed foundation sizing on specific site conditions contact your supplier.

### RSe245 socket for the installation of Ø245mm (9.8in) posts

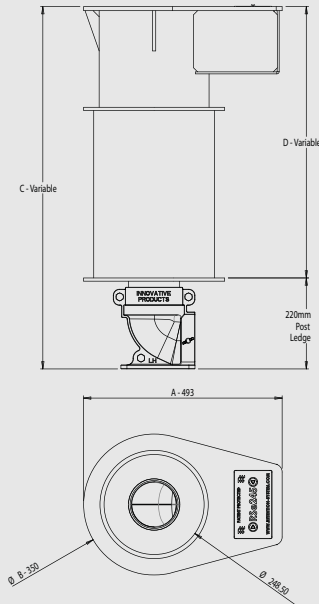

## RSe245

**C\*** RS socket foundation depth  
**D\*\*** post insertion depth

Technical drawings for all RS sockets available from **IPL group**.

*Drawings not to scale, illustrations, technical data, dimensions and weights are subject to alteration without notice.*

Ref No:	Base Type	A (mm)	B (mm)	C* (mm)	D** (mm)	Weight (kg)
<b>RSe245x300sf</b>	shallow foundation	493	350	300	210	55
<b>RSe245x300</b>	standard [flat]	493	350	300	300	45
<b>RSe245x450</b>	standard [flat]	493	350	450	450	47
<b>RSe245x600</b>	standard [flat]	493	350	600	600	49
<b>RSe245x600df</b>	duck foot bend	493	350	600	380	61.4
<b>RSe245x600t</b>	tee bend	493	350	600	380	63
<b>RSe245x750</b>	standard [flat]	493	350	750	750	53
<b>RSe245x750df</b>	duck foot bend	493	350	750	530	63
<b>RSe245x750t</b>	tee bend	493	350	750	530	65
<b>RSe245x900</b>	standard [flat]	493	350	900	900	57
<b>RSe245x900df</b>	duck foot bend	493	350	900	680	65
<b>RSe245x900t</b>	tee bend	493	350	900	680	67

#### Options:

**RS stump pole**

**RSe245x1000 / RSe245x1220df / RSe245x1220t**

(non-standard foundation depths & base types per specification)

#### Material Specification:

Head, Plug, Locking Lid:	Mild Steel
Body:	PVC - Polyvinyl Chloride
Flat Base:	Mild Steel
Duck Foot Bend:	Ductile Iron (BS2789 500-7)
Tee Bend:	Ductile Iron (BS2789 500-7)
Setscrews:	M24 A2 Stainless Steel
Assembly Screws:	M12 A2 Stainless Steel
Finish:	Galvanised

Further information on the RETENTION SYSTEM sockets for post installation is available at [www.retention-system.com](http://www.retention-system.com)  
Measurements and weights are approximate. The designs are the property of Innovative Products Ltd (IPL group) and may not be reproduced without express permission. Innovative Products reserve the right to amend specifications or to withdraw models without prior notice. © July 2013.

