

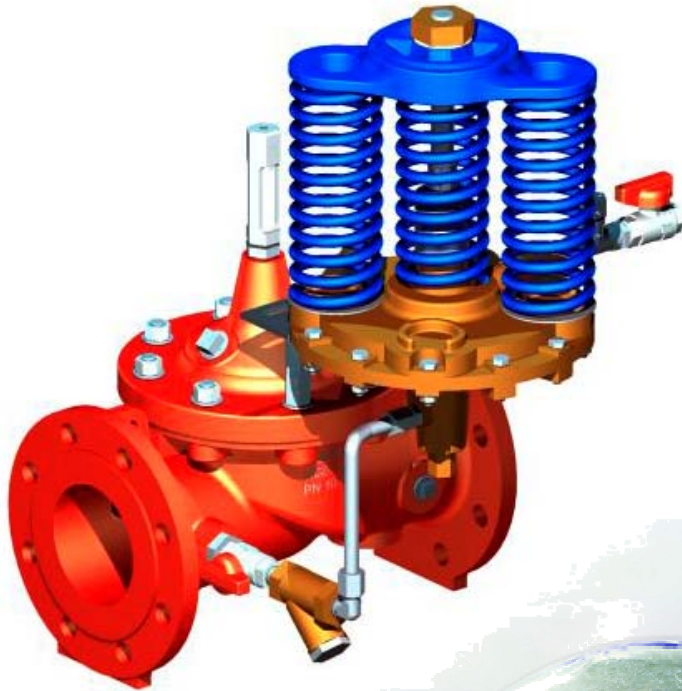

Technical Documentation



- Engineering Capabilities
- Industry Experience
- Certification & Approvals
- Typical Applications
- Global Operations
- Markets & Applications

▶ Table of Contents

- Main Function & Application
- Schematic Diagram
- Operating Data
- Main Valve Description
- Dimensions
- Installation & Maintenance
- Controls & Accessories
- Valve Specification Form



► Simple, Reliable and Accurate

- Completely Automatic Operation
- Easy Adjustment and Maintenance
- Quality Approved Materials
- World Wide Support

► CLA-VAL SERIES 210 Main Function

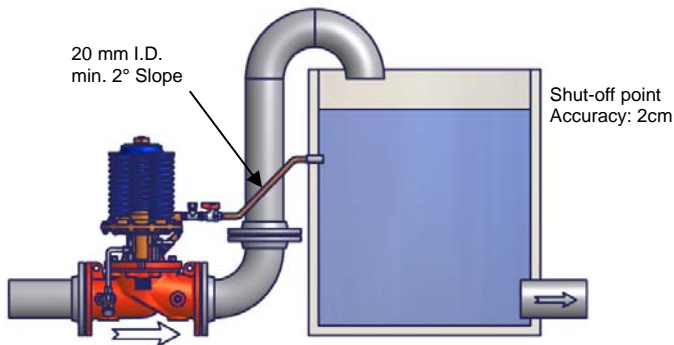

The CLA-VAL SERIES 210 On/Off Altitude Level Control Valve controls the high water level in a reservoir or closed tank without the need for floats or other devices. It is a non-throttling valve that remains fully open until the shut-off point is reached.

► CLA-VAL 210-01 Typical Application

The CLA-VAL 210-01 is typically designed for closed reservoirs where water is withdrawn through a separate line. The desired water level is set by adjusting the spring force. The pilot control operates on the differential in forces between a spring load and the water level in the reservoir.

The CLA-VAL 210-01 is one way flow only. The reservoir pressure sensing line should be 20 mm minimum I.D. installed with 2° slope from the valve to the reservoir to avoid air pockets.

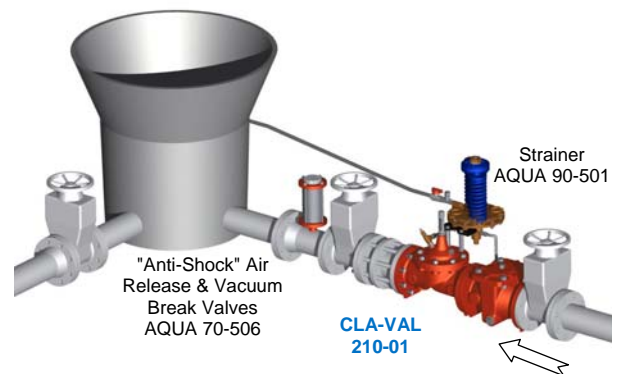

► Usual SERIES 210 Combinations

| | |
|---------------------------------|----------|
| Main Valve | 100-01 |
| Level Control Help Matrix | 000110DE |
| One Level On/Off Control | |
| One-Way Flow Altitude Valve | 210-01 |
| 210-01 + Flow control | 210-21 |
| 210-01 + Check valve | 210-31 |
| 210-01 + Sustaining | 210-66 |
| Two-Way Flow Altitude Valve | 210-16 |
| Two Level On/Off Altitude Valve | 210T-01 |

► Other Functions: Please Contact CLA-VAL

► More Information

| | | | |
|-------------------------------------|------------------------------|---------|----------|
| <input checked="" type="checkbox"/> | Schematic Diagram | Sheet # | 210001FE |
| <input checked="" type="checkbox"/> | Quick Valve Selection | | 000121DE |
| <input checked="" type="checkbox"/> | Dimensions | | 000122DE |
| <input checked="" type="checkbox"/> | Pressure Ratings & Materials | | 000123DE |

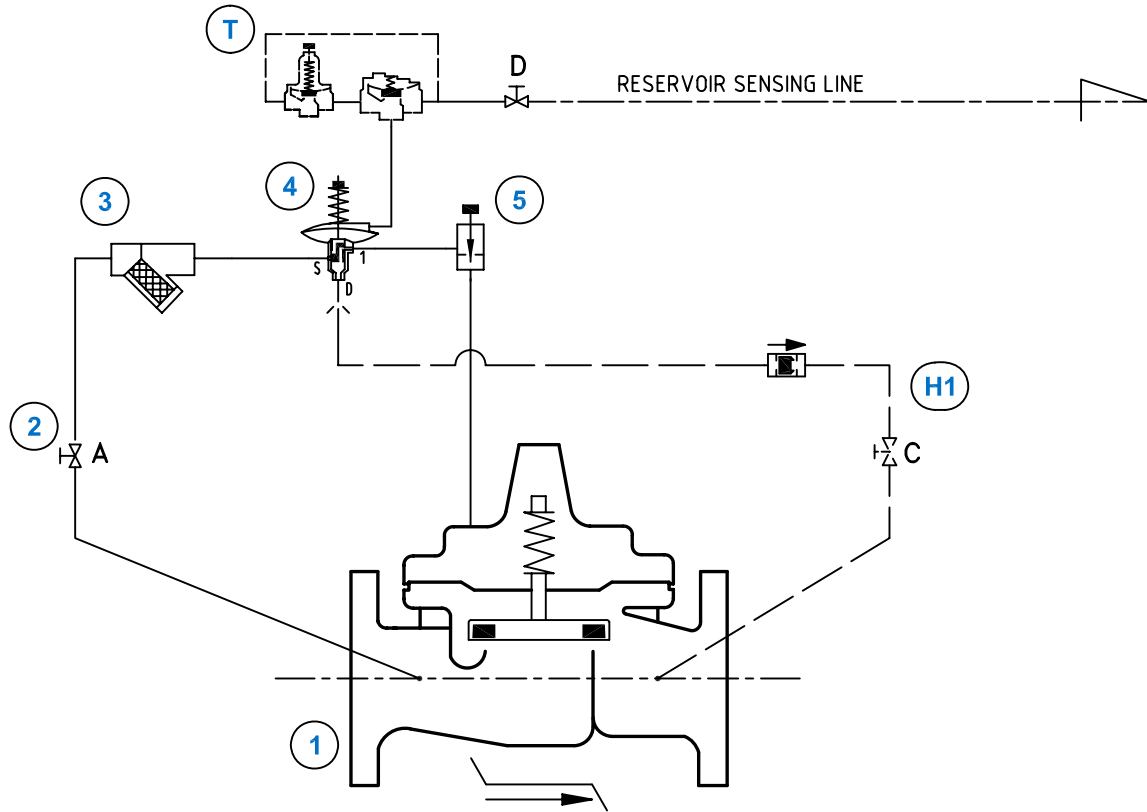

STANDARD EQUIPMENT

| No | Description | Qty | Type |
|----|-------------------------------------|-----|--------|
| 1 | MAIN VALVE HYTROL AE/GE/NGE | 1 | 100-01 |
| 2 | ISOLATION BALL VALVE | 2 | RB-117 |
| 3 | STRAINER | 1 | X43 |
| 4 | 3-WAY ON/OFF ALTITUDE LEVEL CONTROL | 1 | CDS-6A |
| 5 | NEEDLE VALVE | 1 | 6120 |

OPTIONAL FEATURES

| No | Description | Qty | Type |
|----|----------------------------|-----|----------------|
| H1 | DRAIN TO MAIN VALVE OUTLET | 1 | CDC-1 & RB-117 |
| T | DELAYED OPENING | 1 | CVC & 81-01 |

NOTES

AE/GE : DN 32 - DN 400 / NGE : DN 50 - DN 600

OPTIONAL FEATURES : _____
NOT FURNISHED BY CLA-VAL : _____



▶ Operating data

1.1 ▶ ALTITUDE VALVE FEATURE

Altitude control (4) is a spring loaded, 3-way, diaphragm actuated control that senses pressure in the reservoir. When the reservoir pressure (liquid level) is lower than the set point of control (4), ports "I" and "D" are interconnected. This relieves main valve cover pressure to atmosphere and the main valve opens to fill the reservoir. Reservoir sensing pressure increases as the liquid level rises in the reservoir. When reservoir pressure increases to the set point of control (4), control (4) shifts, interconnecting ports "S" and "I". This pressurizes the main valve cover and the main valve closes.

Altitude control (4) adjustment: Turn the spring adjusting nut clockwise to increase the liquid level shutoff point, counter clockwise to decrease the liquid level shutoff point.

1.2 ▶ CLOSING / OPENING SPEED

Needle valve (5) controls the reaction speed and particularly the closing speed of the main valve (1).

Needle valve (5) adjustment: Turn the adjusting screw of needle valve (5) clockwise to make the main valve (1) close slower.

Note: Do not close the needle valves (5) completely or the main valve (1) will not close or open. Recommended adjustment = 1/2 to 1 turn open.

1.3 ▶ (E*) EUROPEAN STANDARDS

ITEM (2) - Isolation ball valve:

The isolation ball valves are used to isolate the pilot system from main line pressure. These isolation ball valves must be open during normal operation.

ITEM (3) - Y-Strainer:

The strainer is installed in the pilot supply line to protect the pilot system from foreign particles. The strainer screen must be cleaned periodically.

1.4 ▶ OPTIONAL FEATURES

Suffix (H1) - Pilot drain to outlet:

Check valve (H) and cock (2C) are used when pilot drain to atmosphere is not desired. When outlet pressure is higher than inlet pressure check valve (H) closes, maintaining main valve (1) in position of partial opening.

Suffix (T) - Delayed opening feature:

Differential control **CVC** is closed during the reservoir filling cycle. As the liquid level rises in the reservoir, check valve **81-01** opens. This directs static reservoir pressure into the sensing chamber of altitude control (4). When the reservoir is filled and the main valve closes, the liquid level has reached the high point and check valve **81-01** closes. As the reservoir level lowers, check valve **81-01** remains closed, trapping pressure in the sensing chamber of altitude control (4). When the level lowers to the desired reopening point, differential control **CVC** opens and releases the trapped pressure from altitude control (4) which shifts, permitting the main valve to reopen and fill the reservoir.

Differential control CVC adjustment: Turn the adjusting screw clockwise to increase the delay of opening.



CLA-VAL 210-01

On/Off Altitude Level Control Valve

1.5 ▶ CHECK LIST FOR PROPER OPERATION

- System valves open upstream and downstream.
- Air removed from the main valve cover and pilot system at all high points.
- Isolation valves **(2)** open.
- Periodical cleaning of the filter screen **(3)**.
- Flow control **(5)** minimum ¼ turn open.
- Reservoir sensing line connected without high point(s) or high point(s) to be equipped with venting cock(s).

▶ Simple, Reliable and Accurate

▶ CLA-VAL SERIES 100 Main Function

The CLA-VAL 100-01 HYTROL Valve is a hydraulically operated, diaphragm actuated, globe or angle pattern valve.

It consists of three major components: body, diaphragm assembly and cover. The diaphragm assembly is the only moving part, guided top and bottom by a precision machined stem. The disc retainer and rubber disc form a drip-tight seal with the renewable seat when pressure is applied above the diaphragm (cover chamber).

The CLA-VAL 100-01 is the basic valve used in nearly in all CLA-VAL Automatic Control Valves.

There are 3 HYTROL body types:

NGE: New Globe Execution
 GE: Globe Execution
 AE: Angle Execution

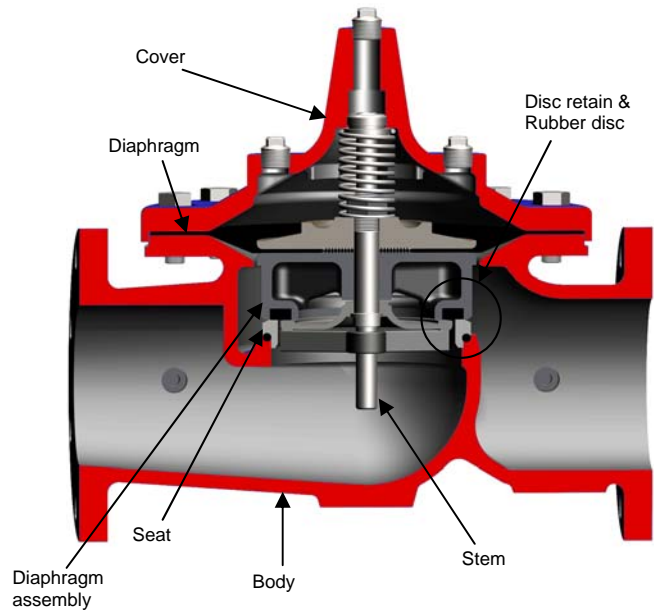

▶ CLA-VAL 100-01 Principle of Operation

On/Off Control

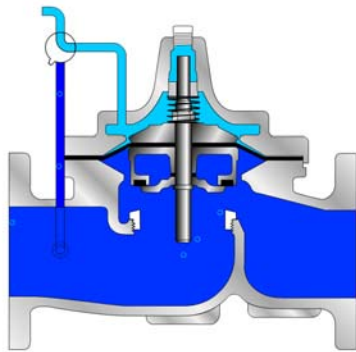

Full Open Operation:
 When pressure in the cover chamber is relieved to a lower pressure or to atmosphere, the pressure inlet opens the valve.

On/Off Control

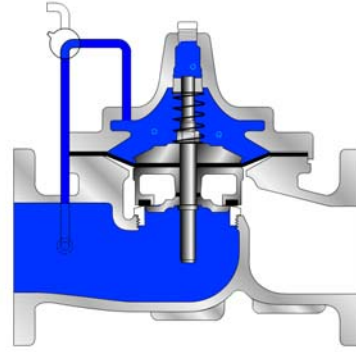

Tight Closing Operation:
 When pressure from the inlet pressure is applied to the cover chamber, the valve closes drip-tight.

CLA-VAL Controls

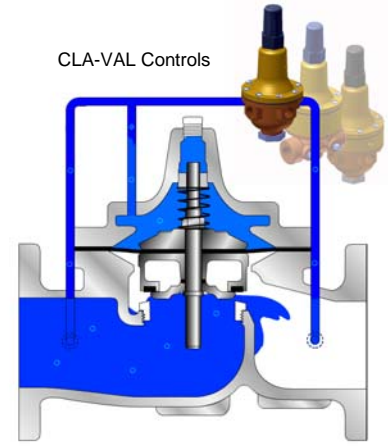

Modulating Control:
 The valve is pressure operating balanced. The CLA-VAL "Modulating" Controls will allow the valve to automatically compensate for pressure changes.

▶ Usual Main Valves

| | |
|------------------------------------|----------|
| HYTROL Main Valve / HYTROL NGE-316 | 100-01 |
| TYTAN Main Valve | 100-01 |
| HYTROL Auxiliary Valve | 000130TT |
| ROLL SEAL Main Valve | 100-42 |
| DELUGE Main Valve | 100G |

▶ More Information

- Schematic Diagram
- Quick Valve Selection
- Dimensions
- Pressure Ratings & Materials

| |
|------------|
| Sheet # |
| HYN001TT |
| 000121DE |
| 000122DE-1 |
| 000123DE |

▶ Other Functions : Please Contact CLA-VAL

► Cavitation / Flow Chart

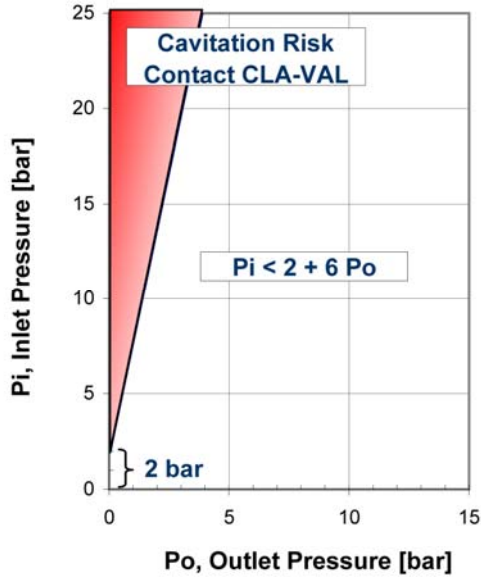

● **Valve Sizing Example**

Pipe Diameter : 100 [mm] }
 Peak Flow : 20 [l/s] } **NGE DN 100 [mm]**

Inlet Pressure : 15 [bar] }
 Outlet Pressure : 5 [bar] } **Below Cavitation Risk**

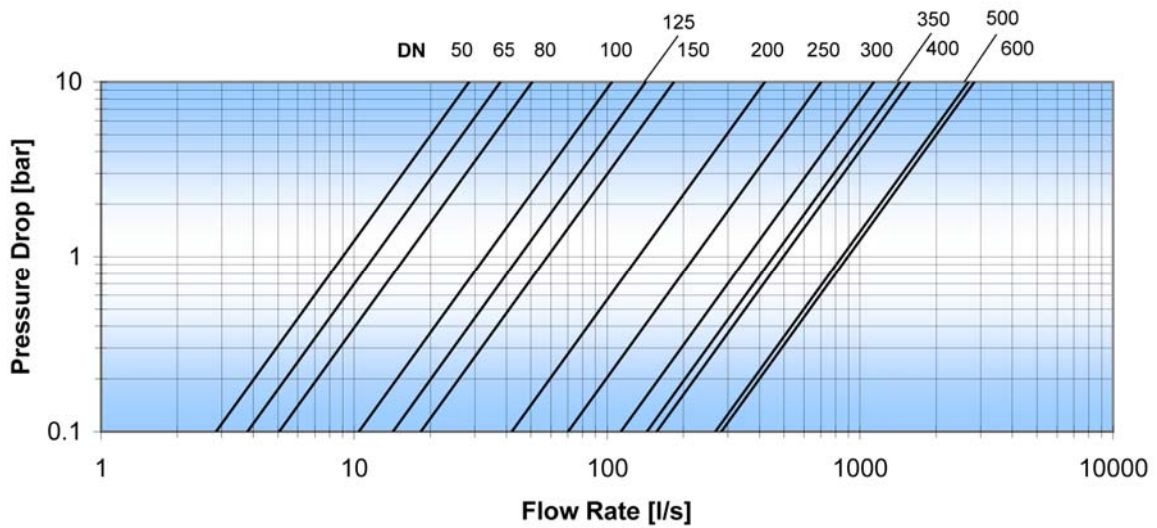

► Notes

- Diagram to be used as a guide only.

► More Information

- Quick Valve Selection
- Sizing Software

Sheet #
 000121DE
 Run CLA-VAL Softwares

► To obtain a more accurate calculation please contact CLA-VAL

▶ Performance Chart

| Flanged [mm] | DN | 32 | 40 | 50 | 65 | 80 | 100 | 125 | 150 | 200 | 250 | 300 | 350 | 400 | 450 | 500 | 600 |
|--------------------------|----|--------|--------|-----|--------|------|------|------|------|------|-----|------|------|------|------|------|------|
| Screwed [in] | DN | 1 1/4" | 1 1/2" | 2" | 2 1/2" | 3" | - | - | - | - | - | - | - | - | - | - | - |
| Hytrol NGE | | | | | | | | | | | | | | | | | |
| Kv (m3/h) | | - | - | 32 | 43 | 58 | 119 | 162 | 209 | 479 | 799 | 1292 | 1638 | 1789 | 2298 | 3049 | 3222 |
| Cv (l/s) @ 1 bar | | - | - | 9 | 12 | 16 | 33 | 45 | 58 | 133 | 222 | 359 | 455 | 497 | 638 | 847 | 895 |
| ζ (-) | | - | - | 9.5 | 15.3 | 19.8 | 11.3 | 14.9 | 18.6 | 11.2 | 9.8 | 7.8 | 8.9 | 12.8 | 12.4 | 10.8 | 20.0 |
| Normal Flow (l/s) | | | | | | | | | | | | | | | | | |
| @ velocity 1 m/s | | | | 1.6 | 2.7 | 4 | 6 | 10 | 14 | 25 | 39 | 56 | 77 | 100 | 127 | 157 | 226 |
| @ velocity 3 m/s | | | | to | to | to | to | to | to | to | to | to | to | to | to | to | to |
| | | | | 6 | 10 | 15 | 24 | 37 | 53 | 94 | 147 | 212 | 289 | 377 | 477 | 589 | 848 |
| Max. Flow (l/s) | | | | | | | | | | | | | | | | | |
| Continuous @ v=4 m/s | | - | - | 8 | 13 | 20 | 31 | 49 | 71 | 126 | 196 | 283 | 385 | 502 | 636 | 785 | 1130 |
| Intermittent @ v=5.5 m/s | | - | - | 11 | 18 | 28 | 43 | 67 | 97 | 173 | 270 | 389 | 529 | 691 | 874 | 1079 | 1554 |

$$Q = Kv \sqrt{\Delta p}$$

$$Q = Cv \sqrt{\Delta p}$$

$$\Delta H = \zeta \frac{v^2}{2g}$$

Q : rate of flow (m3/h)
Kv : flow coefficient (m3/h)
Cv : flow coefficient (l/s)
 Δp : head loss (bar)

ΔH : head loss (m)
v : average pipe velocity (m/s)
g : gravitational constant (9.81m/s²)
 ζ : resistance coefficient (-)

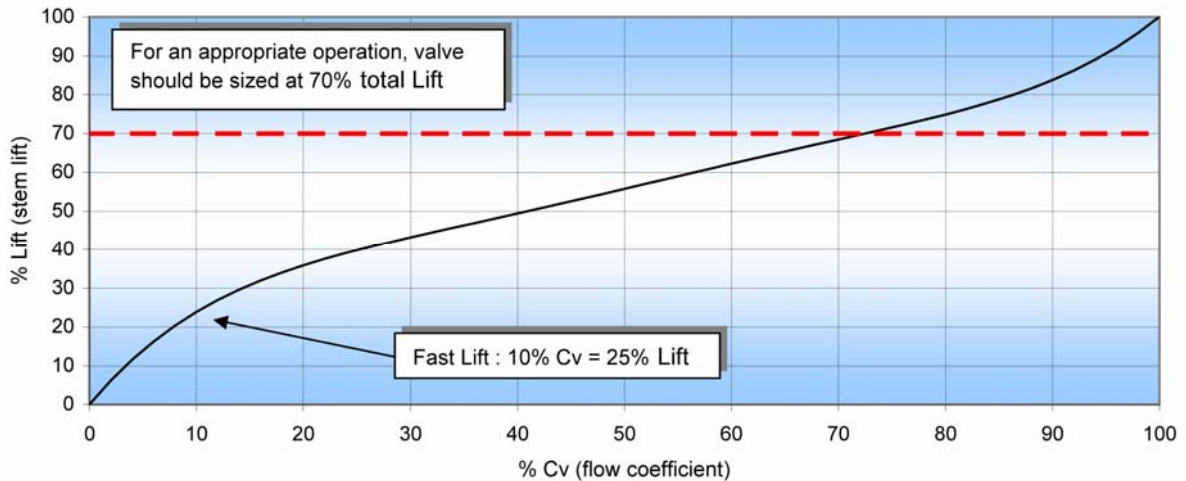

▶ Notes

- Kv or Cv = m3/h or l/s @ 100kPa (1 bar) head loss with 15°C water (valve totally open).
- Minimum Opening Pressure: 0,2 [bar].
- Minimum Differential Pressure: 0,5 [bar].

▶ More Information

- Quick Valve Selection
- Sizing Software

Sheet #

000121DE

Run CLA-VAL Softwares

▶ For lower opening Pressure or differential pressure, please contact CLA-VAL

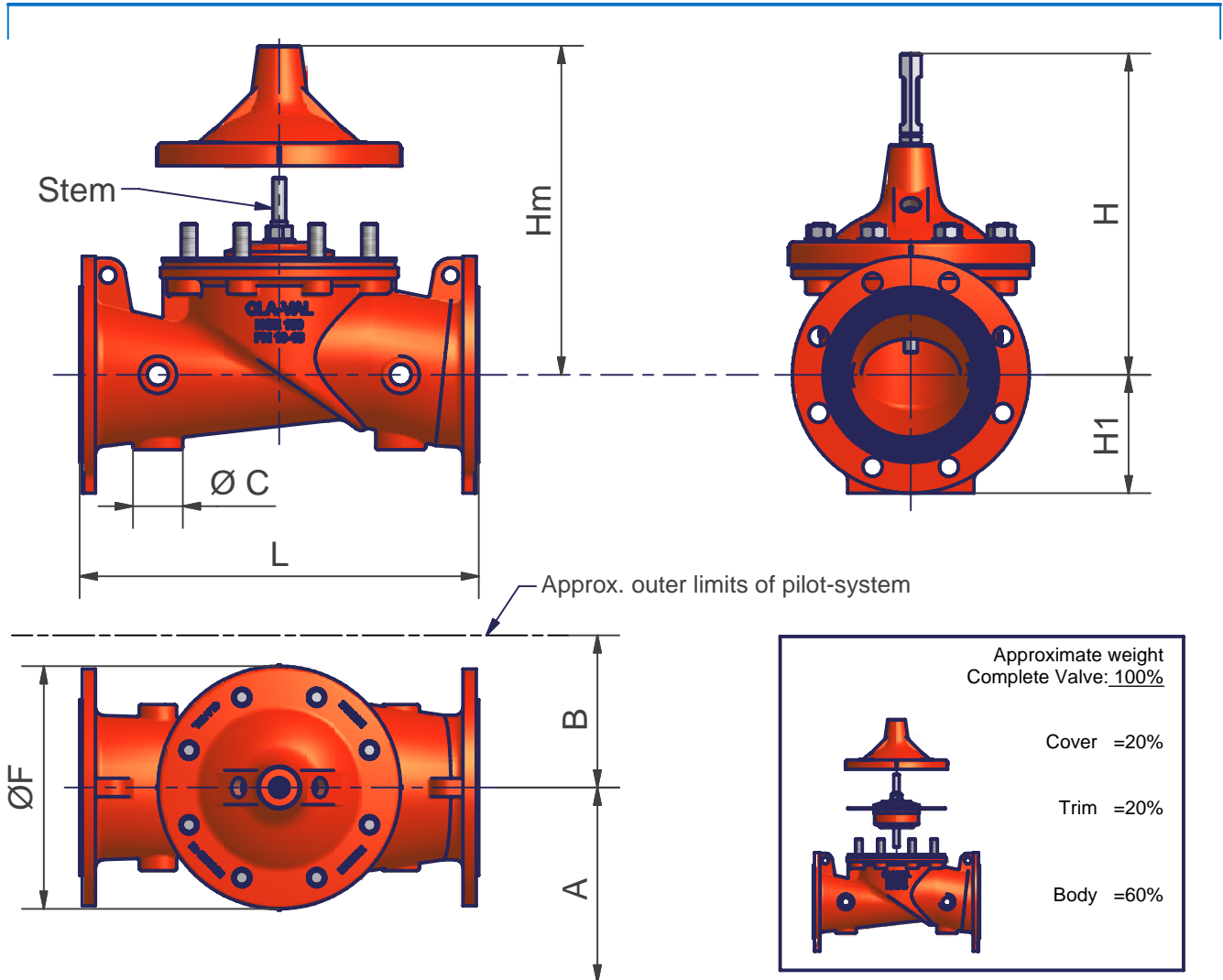

► Technical Data:

| Flanged (mm) | DN 50 | DN 65 | DN 80 | DN 100 | DN 125 | DN 150 | DN 200 | DN 250 | DN 300 | DN 350 | DN 400 | DN 450 | DN 500 | DN 600 |
|--------------|-------|-------|-------|--------|--------|--------|--------|--------|--------|--------|--------|--------|--------|--------|
| L | 230 | 290 | 310 | 350 | 400 | 480 | 600 | 730 | 850 | 980 | 1100 | 1200 | 1250 | 1450 |
| F | 145 | 170 | 170 | 235 | 295 | 295 | 400 | 510 | 600 | 712 | 712 | 712 | 900 | 900 |
| H | 195 | 225 | 230 | 305 | 365 | 375 | 460 | 547 | 695 | 821 | 821 | 900 | 1035 | 1035 |
| H1 (PN10) | 82.5 | 93 | 100 | 110 | 125 | 142.5 | 170 | 200 | 227.5 | 252.5 | 282.5 | 325 | 370 | 430 |
| H1 (PN16) | 82.5 | 93 | 100 | 110 | 125 | 142.5 | 170 | 200 | 227.5 | 260 | 290 | 325 | 370 | 430 |
| H1 (PN25) | 82.5 | 93 | 100 | 117.5 | 135 | 150 | 180 | 212.5 | 242.5 | 277.5 | 310 | 335 | 370 | 430 |
| Hm | 255 | 295 | 300 | 390 | 470 | 480 | 585 | 700 | 875 | 1030 | 1030 | 1200 | 1310 | 1310 |
| A | 190 | 200 | 200 | 200 | 235 | 250 | 270 | 290 | 365 | 400 | 425 | 450 | 520 | 520 |
| B | 145 | 150 | 150 | 160 | 160 | 165 | 200 | 200 | 345 | 385 | 380 | 420 | 460 | 460 |
| øC | 45 | 60 | 60 | 60 | 60 | 80 | 80 | 80 | 80 | 80 | 80 | 80 | - | 120 |
| Weight (Kg) | 15 | 20 | 25 | 40 | 60 | 70 | 120 | 190 | 330 | 540 | 640 | 700 | 980 | 1060 |

► Hydraulic Data:

| Flanged (mm) | DN 50 | DN 65 | DN 80 | DN 100 | DN 125 | DN 150 | DN 200 | DN 250 | DN 300 | DN 350 | DN 400 | DN 450 | DN 500 | DN 600 |
|------------------------|-------|-------|-------|--------|--------|--------|--------|--------|--------|--------|--------|--------|--------|--------|
| Kv (m ³ /h) | 32 | 43 | 58 | 119 | 162 | 209 | 479 | 799 | 1292 | 1638 | 1789 | 2070 | 3049 | 3222 |
| Cv (l/s) | 9 | 12 | 16 | 33 | 45 | 58 | 133 | 222 | 359 | 455 | 497 | 575 | 847 | 895 |

Kv or Cv = m³/h or l/s @ 100kPa (1 bar) head loss with 15°C water (valve totally open).

▶ DN 50 to DN 600

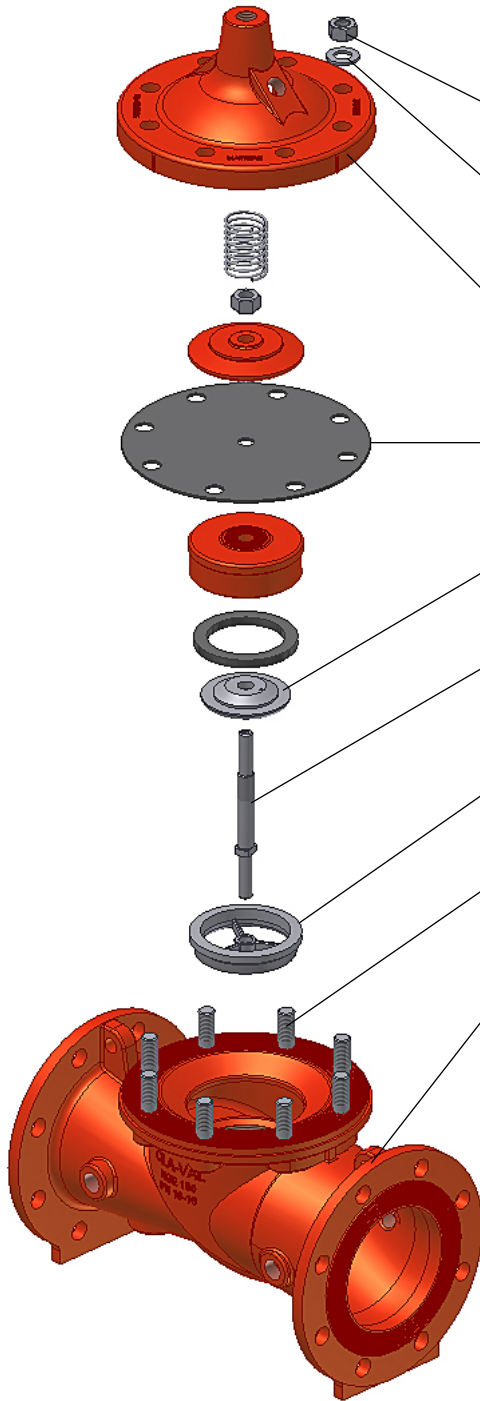

| Standard Materials | | |
|--------------------|------------|-------------------|
| (3) | Stud nut | Stainless Steel |
| (29) | Washer | Stainless Steel |
| (6) | Cover | Ductile Iron |
| (9) | Diaphragm | Reinforced Rubber |
| (11) | Disc guide | Stainless Steel |
| (14) | Stem | Stainless Steel |
| (15) | Seat | Stainless Steel |
| (4) | Stud | Stainless Steel |
| (16) | Body | Ductile Iron |

- Other Pressure Rating on request: PN 40, ANSI 150, ANSI 300.
- Standard epoxy coating minimum 250 microns.
- Auxiliary Valve HYTROL 3/8", 1/2", 3/4", 1" see 000130TT.

► DESCRIPTION

The CLA-VAL Model 100-01 HYTROL Valve is a main valve for CLA-VAL Automatic Control Valves. It is a hydraulically operated, diaphragm-actuated, globe or angle pattern valve.

This valve consists of three major components; body, diaphragm assembly, and cover. The diaphragm assembly is the only moving part. The diaphragm assembly uses a diaphragm of nylon fabric bonded with synthetic rubber. A synthetic rubber disc, contained on three and one half sides by a disc retainer and disc guide, forms a seal with the valve seat when pressure is applied above the diaphragm. The diaphragm assembly forms a sealed chamber in the upper portion of the valve, separating operating pressure from line pressure.

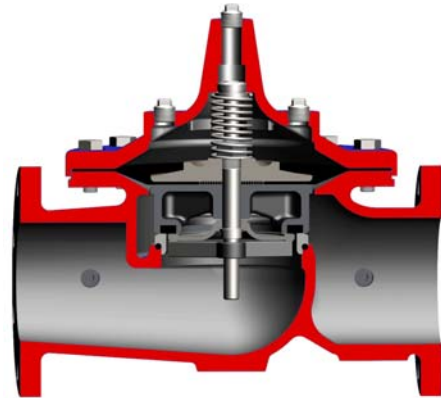

Illustration type GE

► INSTALLATION

1. Before valve is installed, pipe lines should be flushed of all chips, scale and foreign matter.
2. It is recommended that either gate or block valves be installed on both ends of the 100-01 HYTROL Valve to facilitate isolating the valve for preventive maintenance and repairs.
3. Place the valve in the line with flow through the valve in the direction indicated on the inlet nameplate. (See "Flow Direction" Section)
4. Allow sufficient room around valve to make adjustments and for disassembly.
5. CLA-VAL 100-01 HYTROL Valves operate with maximum efficiency when mounted in horizontal piping with the cover UP, however, other positions are acceptable. Due to size and weight of the cover and internal components of 8 inch and larger valves, installation with the cover UP is advisable. This makes internal parts readily accessible for periodic inspection.
6. Caution must be taken in the installation of this valve to insure that galvanic and/or electrolytic action does not take place. The proper use of dielectric fittings and gaskets are required in all systems using dissimilar metals.
7. If a pilot control system is installed on the 100-01 HYTROL Valve, use care to prevent damage. If it is necessary to remove fittings or components, be sure they are kept clean and replaced exactly as they were.
8. After the valve is installed and the system is first pressurized, vent air from the cover chamber and pilot system tubing by loosening fittings at all high points.

► FLOW DIRECTION

The flow through the 100-01 HYTROL Valve can be in one of two directions. When flow is "up-and-over the seat," it is in "normal" flow and the valve will fail in the open position. When flow is "over the seat-and down," it is in "reverse" flow and the valve will fail in the closed position. There are no permanent flow arrow markings.

The valve must be installed according to nameplate data.

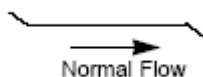

BRIDGEWALL INDICATOR
(cast into side of valve body)

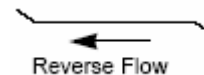

► RECOMMENDED TOOLS

1. Three pressure gauges with ranges suitable to the installation to be put at HYTROL inlet, outlet and cover connections.
2. CLA-VAL Model X101 Valve Position Indicator. This provides visual indication of valve position without disassembly of valve.
3. Other items are: suitable hand tools such as screwdrivers, wrenches, etc. soft jawed (brass or aluminum) vise 400 grit wet or dry sandpaper and water for cleaning.

▶ PRINCIPLES OF OPERATION

(Illustration type GE)

On/Off Control

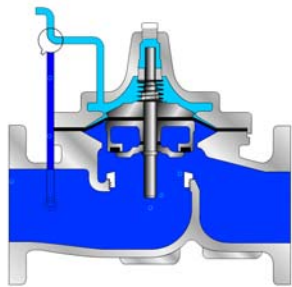

Tight Closing Operation

When pressure from the valve inlet (or an equivalent independent operating pressure) is applied to the diaphragm chamber the valve closes drip-tight.

On/Off Control

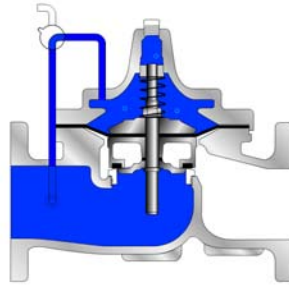

Full Open Operation

When pressure in diaphragm chamber is relieved to a zone of lower pressure (usually atmosphere) the line pressure (5 psi Min.) at the valve inlet opens the valve.

CLA-VAL control

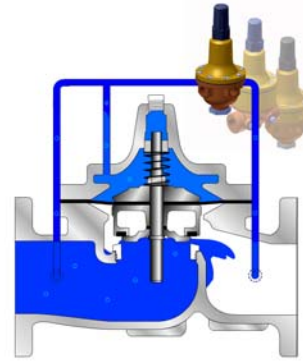

Modulating Action

Valve modulates when diaphragm pressure is held at an intermediate point between inlet and discharge pressure. With the use of a CLA-VAL. "modulating control," which reacts to line pressure changes, the pressure above the diaphragm is varied, allowing the valve to throttle and compensate for the change.

▶ THREE CHECKS

The 100-01 HYTROL Valve has only one moving part (the diaphragm and disc assembly). So, there are only three major types of problems to be considered.

First: Valve is stuck - that is, the diaphragm assembly is not free to move through a full stroke either from open to close or vice versa.

Second: Valve is free to move and can't close because of a worn out diaphragm.

Third: Valve leaks even though it is free to move and the diaphragm isn't leaking.

CAUTION! Care should be taken when doing the troubleshooting checks on the 100-01 HYTROL Valve. These checks do require the valve to open fully. This will either allow a high flow rate through the valve, or the downstream pressure will quickly increase to the inlet pressure. In some cases, this can be very harmful. Where this is the case, and there are no block valves in the system to protect the downstream piping, it should be realized that **the valve cannot be serviced under pressure**. Steps should be taken to remedy this situation before proceeding any further.

| Valve size (DN) | | COVER CHAMBER CAPACITY (liquid Volume displaced when valve opens) | | STEM TRAVEL (Fully Open To Fully closed) | |
|-----------------|------------|--|---------|---|--------|
| NGE | GE | Liters | Gallons | mm | Inches |
| 50 | 32 - 40 | 0,07 | 0,020 | 10,0 | 0,40 |
| 65 & 80 | 50 | 0,12 | 0,032 | 15,0 | 0,60 |
| | 65 | 0,16 | 0,043 | 18,0 | 0,70 |
| 100 | 80 | 0,30 | 0,080 | 20,0 | 0,80 |
| 125 & 150 | 100 | 0,64 | 0,169 | 28,0 | 1,10 |
| 200 | 150 | 2,00 | 0,531 | 43,0 | 1,70 |
| 250 | 200 | 4,80 | 1,260 | 58,0 | 2,30 |
| 300 | 250 | 9,50 | 2,510 | 71,0 | 2,80 |
| 350 & 400 | 300 | 15,10 | 4,000 | 86,0 | 3,40 |
| | 350 | 24,60 | 6,500 | 100,0 | 4,00 |
| 500 & 600 | 400 | 36,20 | 9,570 | 114,0 | 4,50 |
| TYTAN | | Liters | Gallons | mm | Inches |
| TYTAN-S | 600 - 800 | 107,00 | 28,27 | 154,6 | 6,0 |
| TYTAN-M | 900 - 1000 | 159,00 | 42,00 | 190,0 | 7,5 |
| TYTAN-L | 900 - 1200 | 340,00 | 90,00 | 216,0 | 8,5 |



DIAPHRAGM CHECK (#1)

1. Shut off pressure to the HYTROL Valve by slowly closing upstream and downstream isolation valves. **SEE CAUTION!**
2. Disconnect or close all pilot control lines to the valve cover and leave only one fitting in highest point of cover open to atmosphere.
3. With the cover vented to atmosphere, slowly open upstream isolation valve to allow some pressure into the HYTROL Valve body. Observe the open cover tapping for signs of continuous flow. It is not necessary to fully open isolating valve. Volume in cover chamber capacity chart will be displaced as valve moves to open position. Allow sufficient time for diaphragm assembly to shift positions. If there is no continuous flow, you can be quite certain the diaphragm is sound and the diaphragm assembly is tight. If the fluid appears to flow continuously this is a good reason to believe the diaphragm is either damaged or it is loose on the stem. In either case, this is sufficient cause to remove the valve cover and investigate the leakage. (See "Maintenance" Section for procedure.)

FREEDOM OF MOVEMENT CHECK (#2)

4. Determining the HYTROL Valve's freedom of movement can be done by one of two methods.
5. For most valves it can be done after completing Diaphragm Check (Steps 1., 2., and 3.). **SEE CAUTION!** At the end of step 3. the valve should be fully open.
6. If the valve has a CLA-VAL X101 Position Indicator, observe the indicator to see that the valve opens wide. Mark the point of maximum opening.
7. Re-connect enough of the control system to permit the application of inlet pressure to the cover. Open pilot system cock so pressure flows from the inlet into the cover.
8. While pressure is building up in the cover, the valve should close smoothly. There is a hesitation in every HYTROL Valve closure, which can be mistaken for a mechanical bind. The stem will appear to stop moving very briefly before going to the closed position. This slight pause is caused by the diaphragm flexing at a particular point in the valve's travel and is not caused by a mechanical bind.
9. When closed, a mark should be made on the X101 Valve position indicator corresponding to the "closed" position. The distance between the two marks should be approximately the stem travel shown in chart.
10. If the stroke is different than that shown in stem travel chart this is a good reason to believe something is mechanically restricting the stroke of the valve at one end of its travel. If the flow does not stop through the valve when in the indicated "closed" position, the obstruction probably is between the disc and the seat. If the flow does stop, then the obstruction is more likely in the cover. In either case, the cover must be removed, and the obstruction located and removed. The stem should also be checked for scale build-up. (See "Maintenance, section for procedure.)
11. For valves 6" and smaller, the HYTROL Valve's freedom of movement check can also be done after all pressure is removed from the valve. **SEE CAUTION!** After closing inlet and outlet isolation valves and bleeding pressure from the valve, check that the cover chamber and the body are temporarily vented to atmosphere. Insert fabricated tool into threaded hole in top of valve stem, and lift the diaphragm assembly manually. Note any roughness. The diaphragm assembly should move smoothly throughout entire valve stroke. The tool is fabricated from rod that is threaded on one end to fit valve stem and has a "T" bar handle of some kind on the other end for easy gripping. (See chart in Step 4 of "Disassembly" Section.)
12. Place marks on this diaphragm assembly lifting tool when the valve is closed and when manually positioned open. The distance between the two marks should be approximately the stem travel shown in stem travel chart. If the stroke is different than that shown, there is a good reason to believe something is mechanically restricting the stroke of the valve. The cover must be removed, and the obstruction located and removed. The stem should also be checked for scale build-up. (See "Maintenance, section for procedure.)

TIGHT SEALING CHECK (#3)

13. Test for seat leakage after completing checks #1 & #2 (Steps 1. to 12.). **SEE CAUTION!** Close the isolation valve downstream of the HYTROL Valve. Apply inlet pressure to the cover of the valve, wait until it closes. Install a pressure gauge between the two closed valves using one of the two ports in the outlet side of the HYTROL. Watch the pressure gauge. If the pressure begins to climb, then either the downstream isolation valve is permitting pressure to creep back, or the HYTROL is allowing pressure to go through it. Usually the pressure at the HYTROL inlet will be higher than on the isolation valve discharge, so if the pressure goes up to the inlet pressure, you can be sure the HYTROL is leaking. Install another gauge downstream of isolating valve. If the pressure between the valves only goes up to the pressure on the isolation valve discharge, the HYTROL Valve is holding tight, and it was just the isolation valve leaking.

▶ TROUBLESHOOTING

The following troubleshooting information deals strictly with the Model 100-01 HYTROL Valve. This assumes that all other components of the pilot control system have been checked out and are in proper working condition. (See appropriate sections in Technical Manual for complete valve).

All trouble shooting is possible without removing the valve from the line or removing the cover. It is highly recommended to permanently install a Model X101 Valve Position Indicator and three gauges in unused HYTROL inlet, outlet and cover connections.

| SYMPTOM | PROBABLE CAUSE | REMEDY |
|-----------------------|---|--|
| Fails to close | Closed isolation valves in control system, or in main line. | Open Isolation valves. |
| | Lack of cover chamber pressure. | Check upstream pressure, pilot system, strainer, tubing, valves, or needle valves for obstruction. |
| | Diaphragm damaged. (See Diaphragm Check) | Replace diaphragm. |
| | Diaphragm assembly inoperative. Corrosion or excessive scale build-up on valve stem. (See Freedom of Movement Check) | Clean and polish stem. Inspect and replace any damaged or badly eroded part. |
| | Mechanical obstruction. Object lodged in valve. (See Freedom of Movement Check) | Remove obstruction. |
| | Worn disc. (See Tight Sealing Check) | Replace disc. |
| | Badly scored seat. (See Tight Sealing Check) | Replace seat. |
| Fails to open | Closed upstream and/or downstream isolation valves in main line. | Open isolation valves. |
| | Insufficient line pressure. | Check upstream pressure. (Minimum 5 psi flowing line pressure differential.) |
| | Diaphragm assembly inoperative. Corrosion or excessive build-up on valve stem. (See Freedom of Movement Check) | Clean and polish stem. Inspect and replace any damaged or badly eroded part. |
| | Diaphragm damaged. (For valves in "reverse flow" only) | Replace diaphragm. |

After checking out probable causes and remedies, the following three checks can be used to diagnose the nature of the problem before maintenance is started. They must be done in the order shown.

▶ MAINTENANCE

PREVENTATIVE MAINTENANCE

The CLA-VAL Model 100-01 HYTROL Valve requires no lubrication or packing and a minimum of maintenance. However, a periodic inspection schedule should be established to determine how the operating conditions of the system are affecting the valve. The effect of these actions must be determined by inspection.

DISASSEMBLY

Inspection or maintenance can be accomplished without removing the valve from the line. Repair kits with new diaphragm and disc are recommended to be on hand before work begins.



: Maintenance personnel can be injured and equipment damaged if disassembly is attempted with pressure in the valve. **SEE CAUTION!**

1. Close upstream and downstream isolation valves **and independent operating pressure when used** to shut off all pressure to the valve.
2. Loosen tube fittings in the pilot system to remove pressure from valve body and cover chamber. After pressure has been released from the valve, use care to remove the controls and tubing. Note and sketch position of tubing and controls for re-assembly. The schematic in front of the Technical Manual can be used as a guide when reassembling pilot system.
3. Remove cover nuts and remove cover. If the valve has been in service for any length of time, chances are the cover will have to be loosened by driving upward along the edge of the cover with a **dull** cold chisel.

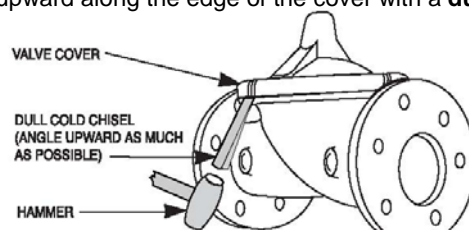

On 6" and smaller valves block and tackle or a power hoist can be used to lift valve cover by inserting proper size eye bolt in place of the center cover plug. On 8" and larger valves there are 4 holes (5/8" - 11 size) where jacking screws and/or eye bolts may be inserted for lifting purposes. **Pull cover straight up** to keep from damaging the integral seat bearing and stem.

| COVER CENTER PLUG SIZE | | |
|------------------------|---------------|-------------------|
| Valve size | | Thread Size (NPT) |
| NGE | GE / AE | |
| DN 50 | DN 32 - 40 | 1/4" |
| DN 65 - 100 | DN 50 - 80 | 1/2" |
| DN 125 - 200 | DN 100 - 150 | 3/4" |
| DN 250 - 300 | DN 200 - 250 | 1" |
| DN 650 - 400 | DN 300 | 1 1/4" |
| - | DN 350 | 1 1/2" |
| DN 500 - 600 | DN 400 | 2" |
| | | |
| TYTAN-S | DN 600 - 800 | 1" |
| TYTAN-M | DN 900 - 1000 | 2" |
| TYTAN-L | DN 900 - 1200 | 2" |

4. Remove the diaphragm and disc assembly from the valve body. With smaller valves this can be accomplished by hand by **pulling straight up on the stem so as not to damage the seat bearing**. On large valves, an eye bolt of proper size can be installed in the stem and the diaphragm assembly can be then lifted with a block and tackle or power hoist. Take care not to damage the stem or bearings. The valve won't work if these are damaged.

| VALVE STEM THREAD SIZE | | |
|------------------------|---------------|------------------------|
| Valve size | | Thread Size (Internal) |
| NGE | GE / AE | |
| DN 50 - 80 | DN 32 - 65 | 10 - 32 UNF |
| DN 100 - 150 | DN 80 - 100 | 1/4 - 28 UNF |
| DN 200 - 400 | DN 150 - 350 | 3/8 - 24 UNF |
| DN 500 - 600 | DN 400 | 1/2 - 20 UNF |
| | | |
| TYTAN-S | DN 600 - 800 | 1/2 - 20 UNF |
| TYTAN-M | DN 900 - 1000 | M20 |
| TYTAN-L | DN 900 - 1200 | M20 |

5. The next item to remove is the stem nut. Examine the stem threads above the nut for signs of mineral deposits or corrosion. If the threads are not clean, use a wire brush to remove as much of the residue as possible. Attach a good fitting wrench to the nut and give it a sharp "rap" rather than a steady pull. Usually several blows are sufficient to loosen the nut for further removal. On the smaller valves, the entire diaphragm assembly can be held by the stem in a vise **equipped with soft brass jaws** before removing the stem nut.

The use of a pipe wrench or a vise without soft brass jaws scars the fine finish on the stem. No amount of careful dressing can restore the stem to its original condition. Damage to the finish of the stem can cause the stem to bind in the bearings and the valve will not open or close.

6. After the stem nut has been removed, the diaphragm assembly breaks down into its component parts. Removal of the disc from the disc retainer can be a problem if the valve has been in service for a long time. Using two screwdrivers inserted along the outside edge of the disc usually will accomplish its removal. Care should be taken to preserve the spacer washers in water, particularly if no new ones are available for re-assembly.
7. The only part left in the valve body is the seat which ordinarily does not require removal. Careful cleaning and polishing of inside and outside surfaces with 400 wet/dry sandpaper will usually restore the seat's sharp edge. If, however, it is badly worn and replacement is necessary, it can be easily removed.

Seats in valve sizes 1 1/4" through 6" are threaded into the valve body. They can be removed with accessory X109 Seat Removing Tool available from the factory. On 8" and larger valves, the seat is held in place by flat head machine screws. Use a tight-fitting, long shank screwdriver to prevent damage to seat screws. If upon removal of the screws the seat cannot be lifted out, it will be necessary to use a piece of angle or channel iron with a hole drilled in the center. Place it across the body so a long stud can be inserted through the center hole in the seat and the hole in the angle iron. By tightening the nut a uniform upward force is exerted on the seat for removal.

Note: Do not lift up on the end of the angle iron as this may force the integral bearing out of alignment, causing the stem to bind.

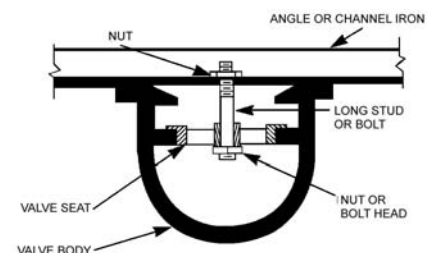



INSPECTION OF PARTS

After the valve has been disassembled, each part should be examined carefully for signs of wear, corrosion, or any other abnormal condition. Usually, it is a good idea to replace the rubber parts (diaphragm and disc) unless they are free of signs of wear. These are available in a repair kit. Any other parts which appear doubtful should be replaced. **WHEN ORDERING PARTS, BE SURE TO GIVE COMPLETE NAMEPLATE DATA, ITEM NUMBER AND DESCRIPTION.**

Note: If a new disc isn't available, the existing disc can be turned over, exposing the unused surface for contact with the seat. The disc should be replaced as soon as practical.

REASSEMBLY

1. Reassembly is the reverse of the disassembly procedure. If a new disc has been installed, it may require a different number of spacer washers to obtain the right amount of "grip" on the disc. When the diaphragm assembly has been tightened to a point where the diaphragm cannot be twisted, the disc should be compressed very slightly by the disc guide. Excessive compression should be avoided. Use just enough spacer washers to hold the disc firmly without noticeable compression.
2. **MAKE SURE THE STEM NUT IS VERY TIGHT.** Attach a good fitting wrench to the nut and give it a sharp "rap" rather than a steady pull. Usually several blows are sufficient to tighten the stem nut for final tightening. Failure to do so could allow the diaphragm to pull loose and tear when subjected to pressure.
3. Carefully install the diaphragm assembly by lowering the stem through the seat bearing. Take care not to damage the stem or bearing. Line up the diaphragm holes with the stud or bolt holes on the body. On larger valves with studs, it may be necessary to hold the diaphragm assembly up part way while putting the diaphragm over the studs.
4. Put spring in place and replace cover. Make sure diaphragm is lying smooth under the cover.
5. Tighten cover nuts firmly using a cross-over pattern until all nuts are tight.
6. Test HYTROL Valve before re-installing pilot valve system.

TEST PROCEDURE AFTER VALVE ASSEMBLY

There are a few simple tests which can be made in the field to make sure the HYTROL Valve has been assembled properly. Do these before installing pilot system and returning valve to service. These are similar to the three troubleshooting tests.

- 1- Check the diaphragm assembly for freedom of movement after all pressure is removed from the valve. **SEE CAUTION!** Insert fabricated tool into threaded hole in top of valve stem, and lift the diaphragm assembly manually. Note any roughness, sticking or grabbing. The diaphragm assembly should move smoothly throughout entire valve stroke. The tool is fabricated from rod that is threaded on one end to fit valve stem (See chart in Step 4 of "Disassembly" section.) and has a "T" Bar handle of some kind on the other end for easy gripping.
Place marks on this diaphragm assembly lifting tool when the valve is closed and when manually positioned open. The distance between the two marks should be approximately the stem travel shown in stem travel chart. (See "Freedom of Movement Check" section.) If the stroke is different than that shown, there is a good reason to believe something is mechanically restricting the stroke of the valve. The cover must be removed, the obstruction located and removed. (See "Maintenance" Section for procedure.) Due to the weight of the diaphragm assembly this procedure is not possible on valves 8" and larger. on these valves, the same determination can be made by carefully introducing a low pressure-less than five psi) into the valve body with the cover vented. **SEE CAUTION!** Looking in cover center hole see the diaphragm assembly lift easily without hesitation, and then settle back easily when the pressure is removed.
- 2- To check the valve for drip-tight closure, a line should be connected from the inlet to the cover, and pressure applied at the inlet of the valve. If properly assembled, the valve should hold tight with as low as ten PSI at the inlet. See "Tight Sealing Check" section.)
- 3- With the line connected from the inlet to the cover, apply full working pressure to the inlet. Check all around the cover for any leaks. Re-tighten cover nuts if necessary to stop leaks past the diaphragm.
- 4- Remove pressure, then re-install the pilot system and tubing exactly as it was prior to removal. **Bleed air from all high points.**
- 5- Follow steps under "Start-Up and Adjustment" Section in Technical Manual for returning complete valve back to service.

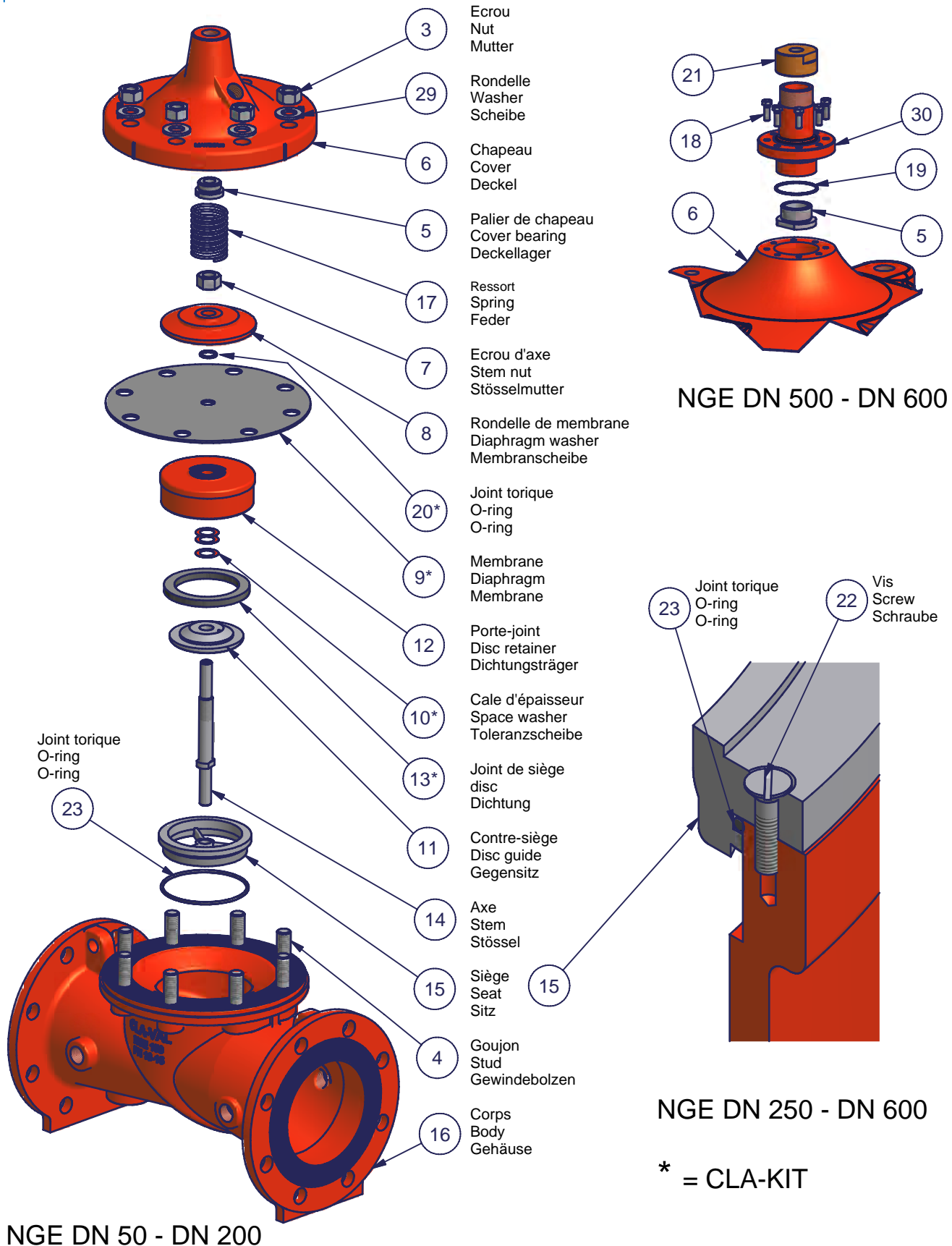

► STD: STANDARD

PIECE DE RECHANGE / SPARE PARTS / ERSATZTEILE

| KIT DE REPARATION / REPAIR KIT / REPARATURSATZ | | |
|--|---|---|
| (a) | CLA-KIT HYTROL100-01 - GE 40/PN 10 - 16 | 91698-04 |
| (b) | CLA-KIT HYTROL100-01 - GE 40/PN 25 |  CLA-VAL |

| POS. | DESCRIPTION | DESCRIPTION | BESCHREIBUNG | MAT. | CLA-VAL Nr. |
|------|-------------------------|---------------------|-------------------------|------|------------------|
| 1 | Bouchon-purgeur | Air release plug | Entlüftungstopfen | 303 | 57576 |
| 2 | Bouchon | Cover plug | Stopfen | 316 | BGT2001 |
| 3 | Ecrou | Stud nut | Mutter | 303 | 67799-08A |
| 4 | Goujon | Stud | Gewindebolzen | 303 | 57621-01 |
| 5 | Palier de chapeau | Cover bearing | Deckellager | 303 | 57933 |
| 6 | Chapeau | Cover | Deckel | FD4 | 57185-40 |
| 7 | Ecrou d'axe | Stem nut | Stößelmutter | 303 | 89375-01J |
| 8 | Rondelle de membrane | Diaphragm washer | Membranscheibe | PLA | 2960701H |
| 9 | Membrane | Diaphragm | Membrane | RBR | 83239E (a) |
| 9.1 | Membrane (PN25) | Diaphragm (PN25) | Membrane (PN25) | RBR | 83239E (2x) (b) |
| 10 | Cale d'épaisseur | Space washer | Toleranzscheibe | FIB | V-5180E (a/b) |
| 11 | Contre-siège | Disc guide | Gegensitz | 316 | C-5446E |
| 12 | Porte-joint | Disc retainer | Dichtungsträger | 303 | C-1862G |
| 13 | Joint de siège | Disc | Dichtung | RBR | V-5562D (a/b) |
| 13.1 | Joint de siège (***) | Disc (***) | Dichtung (***) | PET | 21589-01F (b***) |
| 14 | Axe | Stem | Stößel | 303 | 57286 |
| 15 | Siège | Seat | Sitz | 316 | C-1425C |
| 16 | Corps | Body | Gehäuse | FD4 | (**) |
| 17 | Ressort | Spring | Feder | 302 | C-8477G |
| 17.1 | Ressort renforcé (PN25) | Spring heavy (PN25) | Verstärkte Feder (PN25) | 302 | C-8476G |
| 20 | Joint torique | O-ring | O-Ring | RBR | 00713J (a/b) |
| 23 | Joint torique | O-ring | O-Ring | RBR | 00731A |
| 25 | Bouchon | Plug | Stopfen | 316 | BGT2001 |
| 29 | Rondelle plate | Washer | Unterlegscheibe | 303 | 67747-04J |

(**) Voir / See / Siehe HYT016F

(***) Recommandé si $\Delta P > 16$ bar / Recommended if $\Delta P > 16$ bar / Empfohlen wenn $\Delta P > 16$ bar

KC: Revêtement époxy / Standard epoxy coating / Epoxy-Pulverbeschichtung (minimum 250 μ m)

KCO: KC + Visserie en acier inoxydable / Stainless steel bolts / Deckelschrauben aus Edelstahl

KCS: KC + Siège et contre-siège en acier inoxydable / Stainless steel seat and guide / Sitz und Gegensitz aus Edelstahl

KCOS: KCO + KCS.

► STD: STANDARD

PIECE DE RECHANGE / SPARE PARTS / ERSATZTEILE

| KIT DE REPARATION / REPAIR KIT / REPARATURSATZ | | |
|--|---|------------------|
| (a) | CLA-KIT HYTROL100-01 - GE 50/PN 10 - 16 | 91698-05 |
| (b) | CLA-KIT HYTROL100-01 - GE 50/PN 25 | 🔧 CLA-VAL |

| POS. | DESCRIPTION | DESCRIPTION | BESCHREIBUNG | MAT. | CLA-VAL Nr. |
|------|-------------------------|---------------------|-------------------------|------|------------------|
| 1 | Bouchon-purgeur | Air release plug | Entlüftungstopfen | 303 | 57576 |
| 2 | Bouchon | Cover plug | Stopfen | 316 | BGT2001 |
| 3 | Ecrou | Stud nut | Mutter | 303 | 67801-08E |
| 4 | Goujon | Stud | Gewindebolzen | 303 | 57621-02 |
| 5 | Palier de chapeau | Cover bearing | Deckellager | 303 | 57934 |
| 6 | Chapeau | Cover | Deckel | FD4 | 57186-40 |
| 7 | Ecrou d'axe | Stem nut | Stößelmutter | 303 | 89376-01G |
| 8 | Rondelle de membrane | Diaphragm washer | Membranscheibe | PLA | 2665501K |
| 9 | Membrane | Diaphragm | Membrane | RBR | 80522G (a) |
| 9.1 | Membrane (PN25) | Diaphragm (PN25) | Membrane (PN25) | RBR | C-1493-01 (b) |
| 10 | Cale d'épaisseur | Space washer | Toleranzscheibe | FIB | V-5232D (a/b) |
| 11 | Contre-siège | Disc guide | Gegensitz | 316 | 32560F |
| 12 | Porte-joint | Disc retainer | Dichtungsträger | 303 | 57383-01 |
| 13 | Joint de siège | Disc | Dichtung | RBR | V-5564K (a/b) |
| 13.1 | Joint de siège (***) | Disc (***) | Dichtung (***) | PET | 21265-01C (b***) |
| 14 | Axe | Stem | Stößel | 303 | 57287 |
| 15 | Siège | Seat | Sitz | 316 | C-4135-01C |
| 16 | Corps | Body | Gehäuse | FD4 | (**) |
| 17 | Ressort | Spring | Feder | 302 | C-3147A |
| 17.1 | Ressort renforcé (PN25) | Spring heavy (PN25) | Verstärkte Feder (PN25) | 316 | C-3152A |
| 20 | Joint torique | O-ring | O-Ring | RBR | 00714G (a/b) |
| 23 | Joint torique | O-ring | O-Ring | RBR | 00775H |
| 25 | Bouchon | Plug | Stopfen | 316 | BGT2001 |
| 29 | Rondelle plate | Washer | Unterlegscheibe | 303 | 67748-04G |

(**) Voir / See / Siehe HYT016F

(***) Recommandé si $\Delta P > 16$ bar / Recommended if $\Delta P > 16$ bar / Empfohlen wenn $\Delta P > 16$ bar

KC: Revêtement époxy / Standard epoxy coating / Epoxy-Pulverbeschichtung (minimum 250 μ m)

KCO: KC + Visserie en acier inoxydable / Stainless steel bolts / Deckelschrauben aus Edelstahl

KCS: KC + Siège et contre-siège en acier inoxydable / Stainless steel seat and guide / Sitz und Gegensitz aus Edelstahl

KCOS: KCO + KCS.

► STD: STANDARD

PIECE DE RECHANGE / SPARE PARTS / ERSATZTEILE

| KIT DE REPARATION / REPAIR KIT / REPARATURSATZ | | |
|--|---|------------------|
| (a) | CLA-KIT HYTROL100-01 - GE 50/PN 10 - 16 | 91698-05 |
| (b) | CLA-KIT HYTROL100-01 - GE 50/PN 25 | 🔧 CLA-VAL |

| POS. | DESCRIPTION | DESCRIPTION | BESCHREIBUNG | MAT. | CLA-VAL Nr. |
|------|-------------------------|---------------------|-------------------------|------|------------------|
| 1 | Bouchon-purgeur | Air release plug | Entlüftungstopfen | 303 | 57576 |
| 2 | Bouchon | Cover plug | Stopfen | 316 | BGT2001 |
| 3 | Ecrou | Stud nut | Mutter | 303 | 67801-08E |
| 4 | Goujon | Stud | Gewindebolzen | 303 | 57621-02 |
| 5 | Palier de chapeau | Cover bearing | Deckellager | 303 | 57934 |
| 6 | Chapeau | Cover | Deckel | FD4 | 57186-40 |
| 7 | Ecrou d'axe | Stem nut | Stößelmutter | 303 | 89376-01G |
| 8 | Rondelle de membrane | Diaphragm washer | Membranscheibe | PLA | 2665501K |
| 9 | Membrane | Diaphragm | Membrane | RBR | 80522G (a) |
| 9.1 | Membrane (PN25) | Diaphragm (PN25) | Membrane (PN25) | RBR | C-1493-01 (b) |
| 10 | Cale d'épaisseur | Space washer | Toleranzscheibe | FIB | V-5232D (a/b) |
| 11 | Contre-siège | Disc guide | Gegensitz | 316 | 32560F |
| 12 | Porte-joint | Disc retainer | Dichtungsträger | 303 | 57383-01 |
| 13 | Joint de siège | Disc | Dichtung | RBR | V-5564K (a/b) |
| 13.1 | Joint de siège (***) | Disc (***) | Dichtung (***) | PET | 21265-01C (b***) |
| 14 | Axe | Stem | Stößel | 303 | 57287 |
| 15 | Siège | Seat | Sitz | 316 | C-4135-01C |
| 16 | Corps | Body | Gehäuse | FD4 | (**) |
| 17 | Ressort | Spring | Feder | 302 | C-3147A |
| 17.1 | Ressort renforcé (PN25) | Spring heavy (PN25) | Verstärkte Feder (PN25) | 316 | C-3152A |
| 20 | Joint torique | O-ring | O-Ring | RBR | 00714G (a/b) |
| 23 | Joint torique | O-ring | O-Ring | RBR | 00775H |
| 25 | Bouchon | Plug | Stopfen | 316 | BGT2001 |
| 29 | Rondelle plate | Washer | Unterlegscheibe | 303 | 67748-04G |

(**) Voir / See / Siehe HYT016F

(***) Recommandé si $\Delta P > 16$ bar / Recommended if $\Delta P > 16$ bar / Empfohlen wenn $\Delta P > 16$ bar

KC: Revêtement époxy / Standard epoxy coating / Epoxy-Pulverbeschichtung (minimum 250 μ m)

KCO: KC + Visserie en acier inoxydable / Stainless steel bolts / Deckelschrauben aus Edelstahl

KCS: KC + Siège et contre-siège en acier inoxydable / Stainless steel seat and guide / Sitz und Gegensitz aus Edelstahl

KCOS: KCO + KCS.

► STD: STANDARD

PIECE DE RECHANGE / SPARE PARTS / ERSATZTEILE

| KIT DE REPARATION / REPAIR KIT / REPARATURSATZ | | |
|--|---|---|
| (a) | CLA-KIT HYTROL100-01 - GE 80/PN 10 - 16 | 91698-12 |
| (b) | CLA-KIT HYTROL100-01 - GE 80/PN 25 |  CLA-VAL |

| POS. | DESCRIPTION | DESCRIPTION | BESCHREIBUNG | MAT. | CLA-VAL Nr. |
|------|-------------------------|---------------------|-------------------------|------|------------------|
| 1 | Bouchon-purgeur | Air release plug | Entlüftungstopfen | 303 | 57576-02 |
| 2 | Bouchon | Cover plug | Stopfen | 316 | BGT3001 |
| 3 | Ecrou | Stud nut | Mutter | 303 | 67805-08F |
| 4 | Goujon | Stud | Gewindebolzen | 303 | 57621-04 |
| 5 | Palier de chapeau | Cover bearing | Deckellager | 303 | 57935 |
| 6 | Chapeau | Cover | Deckel | FD4 | 57188-40 |
| 7 | Ecrou d'axe | Stem nut | Stösselmutter | 303 | 89377-01E |
| 8 | Rondelle de membrane | Diaphragm washer | Membranscheibe | FTG | V-5447/KC |
| 9 | Membrane | Diaphragm | Membrane | RBR | 83241A (a) |
| 9.1 | Membrane (PN25) | Diaphragm (PN25) | Membrane (PN25) | RBR | C-8262C (b) |
| 10 | Cale d'épaisseur | Space washer | Toleranzscheibe | FIB | V-0631B (a/b) |
| 11 | Contre-siège | Disc guide | Gegensitz | 316 | C-7389E |
| 12 | Porte-joint | Disc retainer | Dichtungsträger | FTG | V-5449/KC |
| 13 | Joint de siège | Disc | Dichtung | RBR | V-1734C (a/b) |
| 13.1 | Joint de siège (***) | Disc (***) | Dichtung (***) | PET | 21267-01J (b***) |
| 14 | Axe | Stem | Stössel | 303 | 57289 |
| 15 | Siège | Seat | Sitz | 316 | C-7391A |
| 16 | Corps | Body | Gehäuse | FD4 | (**) |
| 17 | Ressort | Spring | Feder | 302 | C-3149G |
| 17.1 | Ressort renforcé (PN25) | Spring heavy (PN25) | Verstärkte Feder (PN25) | 316 | C-1106J |
| 20 | Joint torique | O-ring | O-Ring | RBR | 00750A (a/b) |
| 23 | Joint torique | O-ring | O-Ring | RBR | 00788A |
| 25 | Bouchon | Plug | Stopfen | 316 | BGT3001 |
| 29 | Rondelle plate | Washer | Unterlegscheibe | 303 | 67750-04C |

(**) Voir / See / Siehe HYT016F

(***) Recommandé si $\Delta P > 16$ bar / Recommended if $\Delta P > 16$ bar / Empfohlen wenn $\Delta P > 16$ bar

KC: Revêtement époxy / Standard epoxy coating / Epoxy-Pulverbeschichtung (minimum 250 μ m)

KCO: KC + Visserie en acier inoxydable / Stainless steel bolts / Deckelschrauben aus Edelstahl

KCS: KC + Siège et contre-siège en acier inoxydable / Stainless steel seat and guide / Sitz und Gegensitz aus Edelstahl

KCOS: KCO + KCS.

► STD: STANDARD

PIECE DE RECHANGE / SPARE PARTS / ERSATZTEILE

| KIT DE REPARATION / REPAIR KIT / REPARATURSATZ | | |
|--|--|------------------|
| (a) | CLA-KIT HYTROL100-01 - GE 100/PN 10 - 16 | 91698-13 |
| (b) | CLA-KIT HYTROL100-01 - GE 100/PN 25 | 🔧 CLA-VAL |

| POS. | DESCRIPTION | DESCRIPTION | BESCHREIBUNG | MAT. | CLA-VAL Nr. |
|------|-------------------------|---------------------|-------------------------|------|------------------|
| 1 | Bouchon-purgeur | Air release plug | Entlüftungstopfen | 303 | 57576-02 |
| 2 | Bouchon | Cover plug | Stopfen | 316 | BGT4001 |
| 3 | Ecrou | Stud nut | Mutter | 303 | 67811-08D |
| 4 | Goujon | Stud | Gewindebolzen | 303 | 37048-02C |
| 5 | Palier de chapeau | Cover bearing | Deckellager | 303 | 57936 |
| 6 | Chapeau | Cover | Deckel | FD4 | 57189-40 |
| 7 | Ecrou d'axe | Stem nut | Stößelmutter | 303 | 89378-01C |
| 8 | Rondelle de membrane | Diaphragm washer | Membranscheibe | FTG | V-5420/KC |
| 9 | Membrane | Diaphragm | Membrane | RBR | 86807F (a) |
| 9.1 | Membrane (PN25) | Diaphragm (PN25) | Membrane (PN25) | RBR | C-8184J (b) |
| 10 | Cale d'épaisseur | Space washer | Toleranzscheibe | FIB | V-0634F (a/b) |
| 11 | Contre-siège | Disc guide | Gegensitz | 316 | 31052E |
| 12 | Porte-joint | Disc retainer | Dichtungsträger | FTG | V-5457/KC |
| 13 | Joint de siège | Disc | Dichtung | RBR | V-5467F (a/b) |
| 13.1 | Joint de siège (***) | Disc (***) | Dichtung (***) | PET | 21268-01G (b***) |
| 14 | Axe | Stem | Stößel | 303 | 57290 |
| 15 | Siège | Seat | Sitz | 316 | 31053C |
| 16 | Corps | Body | Gehäuse | FD4 | (**) |
| 17 | Ressort | Spring | Feder | 302 | C-1533D |
| 17.1 | Ressort renforcé (PN25) | Spring heavy (PN25) | Verstärkte Feder (PN25) | 302 | C-1408J |
| 20 | Joint torique | O-ring | O-Ring | RBR | 00752G (a/b) |
| 23 | Joint torique | O-ring | O-Ring | RBR | 00836H |
| 25 | Bouchon | Plug | Stopfen | 316 | BGT4001 |
| 29 | Rondelle plate | Washer | Unterlegscheibe | 303 | 67753-04G |

(**) Voir / See / Siehe HYT016F

(***) Recommandé si $\Delta P > 16$ bar / Recommended if $\Delta P > 16$ bar / Empfohlen wenn $\Delta P > 16$ bar

KC: Revêtement époxy / Standard epoxy coating / Epoxy-Pulverbeschichtung (minimum 250 μ m)

KCO: KC + Visserie en acier inoxydable / Stainless steel bolts / Deckelschrauben aus Edelstahl

KCS: KC + Siège et contre-siège en acier inoxydable / Stainless steel seat and guide / Sitz und Gegensitz aus Edelstahl

KCOS: KCO + KCS.

► STD: STANDARD

PIECE DE RECHANGE / SPARE PARTS / ERSATZTEILE

| KIT DE REPARATION / REPAIR KIT / REPARATURSATZ | | |
|--|--|------------------|
| (a) | CLA-KIT HYTROL100-01 - GE 100/PN 10 - 16 | 91698-13 |
| (b) | CLA-KIT HYTROL100-01 - GE 100/PN 25 | 🔧 CLA-VAL |

| POS. | DESCRIPTION | DESCRIPTION | BESCHREIBUNG | MAT. | CLA-VAL Nr. |
|------|-------------------------|---------------------|-------------------------|------|------------------|
| 1 | Bouchon-purgeur | Air release plug | Entlüftungstopfen | 303 | 57576-02 |
| 2 | Bouchon | Cover plug | Stopfen | 316 | BGT4001 |
| 3 | Ecrou | Stud nut | Mutter | 303 | 67811-08D |
| 4 | Goujon | Stud | Gewindebolzen | 303 | 37048-02C |
| 5 | Palier de chapeau | Cover bearing | Deckellager | 303 | 57936 |
| 6 | Chapeau | Cover | Deckel | FD4 | 57189-40 |
| 7 | Ecrou d'axe | Stem nut | Stößelmutter | 303 | 89378-01C |
| 8 | Rondelle de membrane | Diaphragm washer | Membranscheibe | FTG | V-5420/KC |
| 9 | Membrane | Diaphragm | Membrane | RBR | 86807F (a) |
| 9.1 | Membrane (PN25) | Diaphragm (PN25) | Membrane (PN25) | RBR | C-8184J (b) |
| 10 | Cale d'épaisseur | Space washer | Toleranzscheibe | FIB | V-0634F (a/b) |
| 11 | Contre-siège | Disc guide | Gegensitz | 316 | 31052E |
| 12 | Porte-joint | Disc retainer | Dichtungsträger | FTG | V-5457/KC |
| 13 | Joint de siège | Disc | Dichtung | RBR | V-5467F (a/b) |
| 13.1 | Joint de siège (***) | Disc (***) | Dichtung (***) | PET | 21268-01G (b***) |
| 14 | Axe | Stem | Stößel | 303 | 57290 |
| 15 | Siège | Seat | Sitz | 316 | 31053C |
| 16 | Corps | Body | Gehäuse | FD4 | (**) |
| 17 | Ressort | Spring | Feder | 302 | C-1533D |
| 17.1 | Ressort renforcé (PN25) | Spring heavy (PN25) | Verstärkte Feder (PN25) | 302 | C-1408J |
| 20 | Joint torique | O-ring | O-Ring | RBR | 00752G (a/b) |
| 23 | Joint torique | O-ring | O-Ring | RBR | 00836H |
| 25 | Bouchon | Plug | Stopfen | 316 | BGT4001 |
| 29 | Rondelle plate | Washer | Unterlegscheibe | 303 | 67753-04G |

(**) Voir / See / Siehe HYT016F

(***) Recommandé si $\Delta P > 16$ bar / Recommended if $\Delta P > 16$ bar / Empfohlen wenn $\Delta P > 16$ bar

KC: Revêtement époxy / Standard epoxy coating / Epoxy-Pulverbeschichtung (minimum 250 μ m)

KCO: KC + Visserie en acier inoxydable / Stainless steel bolts / Deckelschrauben aus Edelstahl

KCS: KC + Siège et contre-siège en acier inoxydable / Stainless steel seat and guide / Sitz und Gegensitz aus Edelstahl

KCOS: KCO + KCS.

► STD: STANDARD

PIECE DE RECHANGE / SPARE PARTS / ERSATZTEILE

| KIT DE REPARATION / REPAIR KIT / REPARATURSATZ | | |
|--|--|---|
| (a) | CLA-KIT HYTROL100-01 - GE 150/PN 10 - 16 | 91698-15 |
| (b) | CLA-KIT HYTROL100-01 - GE 150/PN 25 |  CLA-VAL |

| POS. | DESCRIPTION | DESCRIPTION | BESCHREIBUNG | MAT. | CLA-VAL Nr. |
|------|-------------------------|---------------------|-------------------------|------|------------------|
| 1 | Bouchon-purgeur | Air release plug | Entlüftungstopfen | 303 | 57576-02 |
| 2 | Bouchon | Cover plug | Stopfen | 316 | BGT4001 |
| 3 | Ecrou | Stud nut | Mutter | 303 | 67811-08D |
| 4 | Goujon | Stud | Gewindebolzen | 303 | 37048-02C |
| 5 | Palier de chapeau | Cover bearing | Deckellager | 303 | C-0974A |
| 6 | Chapeau | Cover | Deckel | FD4 | 57190-40 |
| 7 | Ecrou d'axe | Stem nut | Stößelmutter | 303 | 89379-01A |
| 8 | Rondelle de membrane | Diaphragm washer | Membranscheibe | FTG | V-5521/KC |
| 9 | Membrane | Diaphragm | Membrane | RBR | 87893E (a) |
| 9.1 | Membrane (PN25) | Diaphragm (PN25) | Membrane (PN25) | RBR | C-6365F (b) |
| 10 | Cale d'épaisseur | Space washer | Toleranzscheibe | FIB | V-5138C (a/b) |
| 11 | Contre-siège | Disc guide | Gegensitz | 316 | C-7148E |
| 12 | Porte-joint | Disc retainer | Dichtungsträger | FTG | V-1672/KC |
| 13 | Joint de siège | Disc | Dichtung | RBR | V-1692C (a/b) |
| 13.1 | Joint de siège (***) | Disc (***) | Dichtung (***) | PET | 21269-01E (b***) |
| 14 | Axe | Stem | Stößel | 303 | 57291 |
| 15 | Siège | Seat | Sitz | 316 | C-7150A |
| 16 | Corps | Body | Gehäuse | FD4 | (**) |
| 17 | Ressort | Spring | Feder | 302 | C-1534B |
| 17.1 | Ressort renforcé (PN25) | Spring heavy (PN25) | Verstärkte Feder (PN25) | 316 | C-1409G |
| 20 | Joint torique | O-ring | O-Ring | RBR | 00941F (a/b) |
| 23 | Joint torique | O-ring | O-Ring | RBR | 00851G |
| 25 | Bouchon | Plug | Stopfen | 316 | BGT4001 |
| 29 | Rondelle plate | Washer | Unterlegscheibe | 303 | 67753-04G |

(**) Voir / See / Siehe HYT016F

(***) Recommandé si $\Delta P > 16$ bar / Recommended if $\Delta P > 16$ bar / Empfohlen wenn $\Delta P > 16$ bar

KC: Revêtement époxy / Standard epoxy coating / Epoxy-Pulverbeschichtung (minimum 250 μ m)

KCO: KC + Visserie en acier inoxydable / Stainless steel bolts / Deckelschrauben aus Edelstahl

KCS: KC + Siège et contre-siège en acier inoxydable / Stainless steel seat and guide / Sitz und Gegensitz aus Edelstahl

KCOS: KCO + KCS.

► STD: STANDARD

PIECE DE RECHANGE / SPARE PARTS / ERSATZTEILE

| KIT DE REPARATION / REPAIR KIT / REPARATURSATZ | | |
|--|--|------------------|
| (a) | CLA-KIT HYTROL100-01 - GE 200/PN 10 - 16 | 91698-30 |
| (b) | CLA-KIT HYTROL100-01 - GE 200/PN 25 | 🔧 CLA-VAL |

| POS. | DESCRIPTION | DESCRIPTION | BESCHREIBUNG | MAT. | CLA-VAL Nr. |
|------|----------------------|-------------------|-------------------|------|------------------|
| 1 | Bouchon-purgeur | Air release plug | Entlüftungstopfen | 303 | 57576-02 |
| 2 | Bouchon | Cover plug | Stopfen | 316 | BGT6001 |
| 3 | Ecrou | Stud nut | Mutter | 303 | 67811-08D |
| 4 | Goujon | Stud | Gewindebolzen | 303 | 37048-02C |
| 5 | Palier de chapeau | Cover bearing | Deckellager | 303 | C-7414A |
| 6 | Chapeau | Cover | Deckel | FD4 | 57191-40 |
| 7 | Ecrou d'axe | Stem nut | Stößelmutter | 303 | 89380-01J |
| 8 | Rondelle de membrane | Diaphragm washer | Membranscheibe | FTG | V-1354/KC |
| 9 | Membrane | Diaphragm | Membrane | RBR | V-5125K (a) |
| 9.1 | Membrane (PN 25) | Diaphragm (PN 25) | Membrane (PN 25) | RBR | V-5571E (b) |
| 10 | Cale d'épaisseur | Space washer | Toleranzscheibe | FIB | V-5133D (a/b) |
| 11 | Contre-siège | Disc guide | Gegensitz | 316 | 46698H |
| 12 | Porte-joint | Disc retainer | Dichtungsträger | FTG | V-1356/KC |
| 13 | Joint de siège | Disc | Dichtung | RBR | V-5566E (a/b) |
| 13.1 | Joint de siège (***) | Disc (***) | Dichtung (***) | PET | 21270-01C (b***) |
| 14 | Axe | Stem | Stößel | 303 | V-1353B |
| 15 | Siège | Seat | Sitz | 316 | 46699F |
| 16 | Corps | Body | Gehäuse | FD4 | (**) |
| 17 | Ressort | Spring | Feder | 302 | C-7948H |
| 20 | Joint torique | O-ring | O-Ring | RBR | 00758D (a/b) |
| 22 | Vis (8x) | Screw (8x) | Schraube (8x) | 303 | 67972-25H |
| 23 | Joint torique | O-ring | O-Ring | RBR | 00982K |
| 25 | Bouchon | Plug | Stopfen | 316 | BGT6001 |
| 29 | Rondelle plate | Washer | Unterlegscheibe | 303 | 67753-04G |

(**) Voir / See / Siehe HYT016F

(***) Recommandé si $\Delta P > 16$ bar / Recommended if $\Delta P > 16$ bar / Empfohlen wenn $\Delta P > 16$ bar

KC: Revêtement époxy / Standard epoxy coating / Epoxy-Pulverbeschichtung (minimum 250 μm)

KCO: KC + Visserie en acier inoxydable / Stainless steel bolts / Deckelschrauben aus Edelstahl

KCS: KC + Siège et contre-siège en acier inoxydable / Stainless steel seat and guide / Sitz und Gegensitz aus Edelstahl

KCOS: KCO + KCS.

► STD: STANDARD

PIECE DE RECHANGE / SPARE PARTS / ERSATZTEILE

| KIT DE REPARATION / REPAIR KIT / REPARATURSATZ | | |
|--|--|------------------|
| (a) | CLA-KIT HYTROL100-01 - GE 250/PN 10 - 16 | 91698-31 |
| (b) | CLA-KIT HYTROL100-01 - GE 250/PN 25 | 🔧 CLA-VAL |

| POS. | DESCRIPTION | DESCRIPTION | BESCHREIBUNG | MAT. | CLA-VAL Nr. |
|------|----------------------|-------------------|-------------------|------|------------------|
| 1 | Bouchon-purgeur | Air release plug | Entlüftungstopfen | 303 | 57576-02 |
| 2 | Bouchon | Cover plug | Stopfen | 316 | BGT6001 |
| 3 | Ecrou | Stud nut | Mutter | SST | 67814-08H |
| 4 | Goujon | Stud | Gewindebolzen | 303 | 57621-08 |
| 5 | Palier de chapeau | Cover bearing | Deckellager | 303 | C-8611A |
| 6 | Chapeau | Cover | Deckel | FD4 | 57192-40 |
| 7 | Ecrou d'axe | Stem nut | Stößelmutter | 303 | 25925-01H |
| 8 | Rondelle de membrane | Diaphragm washer | Membranscheibe | FTG | V-1778/KC |
| 9 | Membrane | Diaphragm | Membrane | RBR | V-5576D (a) |
| 9.1 | Membrane (PN 25) | Diaphragm (PN 25) | Membrane (PN 25) | RBR | 1650301D (b) |
| 10 | Cale d'épaisseur | Space washer | Toleranzscheibe | FIB | V-5160G (a/b) |
| 11 | Contre-siège | Disc guide | Gegensitz | 316 | C-7957-01G |
| 12 | Porte-joint | Disc retainer | Dichtungsträger | FTG | V-1774/KC |
| 13 | Joint de siège | Disc | Dichtung | NBR | V-5569J (a/b) |
| 13.1 | Joint de siège (***) | Disc (***) | Dichtung (***) | PET | 21271-01A (b***) |
| 14 | Axe | Stem | Stößel | 303 | V-1789G |
| 15 | Siège | Seat | Sitz | 316 | C-7958-01E |
| 16 | Corps | Body | Gehäuse | FD4 | (*) |
| 17 | Ressort | Spring | Feder | SST | C-9113G |
| 20 | Joint torique | O-ring | O-Ring | RBR | 00760K (a/b) |
| 22 | Vis (10x) | Screw (10x) | Schraube (10x) | 303 | 67972-25H |
| 23 | Joint torique | O-ring | O-Ring | RBR | 00865G |
| 25 | Bouchon | Plug | Stopfen | 316 | BGT6001 |
| 29 | Rondelle plate | Washer | Unterlegscheibe | 304 | 67754-04 |

(**) Voir / See / Siehe HYT016F

(***) Recommandé si $\Delta P > 16$ bar / Recommended if $\Delta P > 16$ bar / Empfohlen wenn $\Delta P > 16$ bar

KC: Revêtement époxy / Standard epoxy coating / Epoxy-Pulverbeschichtung (minimum 250 μ m)

KCO: KC + Visserie en acier inoxydable / Stainless steel bolts / Deckelschrauben aus Edelstahl

KCS: KC + Siège et contre-siège en acier inoxydable / Stainless steel seat and guide / Sitz und Gegensitz aus Edelstahl

KCOS: KCO + KCS.

► STD: STANDARD

PIECE DE RECHANGE / SPARE PARTS / ERSATZTEILE

| KIT DE REPARATION / REPAIR KIT / REPARATURSATZ | | |
|--|--|------------------|
| (a) | CLA-KIT HYTROL100-01 - GE 300/PN 10 - 16 | 91698-32 |
| (b) | CLA-KIT HYTROL100-01 - GE 300/PN 25 | 🔧 CLA-VAL |

| POS. | DESCRIPTION | DESCRIPTION | BESCHREIBUNG | MAT. | CLA-VAL Nr. |
|------|----------------------|-------------------|-------------------|------|------------------|
| 1 | Bouchon-purgeur | Air release plug | Entlüftungstopfen | 303 | 57576-02 |
| 2 | Bouchon | Cover plug | Stopfen | 316 | BGT6001 |
| 3 | Ecrou | Stud nut | Mutter | 303 | 67818-08J |
| 4 | Goujon | Stud | Gewindebolzen | 303 | V-6896-02A |
| 5 | Palier de chapeau | Cover bearing | Deckellager | 303 | C-8682B |
| 6 | Chapeau | Cover | Deckel | FD4 | 57193-40 |
| 7 | Ecrou d'axe | Stem nut | Stößelmutter | 303 | 25926-01F |
| 8 | Rondelle de membrane | Diaphragm washer | Membranscheibe | FTG | V5121/KC |
| 9 | Membrane | Diaphragm | Membrane | RBR | V-5544B (a) |
| 9.1 | Membrane (PN 25) | Diaphragm (PN 25) | Membrane (PN 25) | RBR | 1649801G (b) |
| 10 | Cale d'épaisseur | Space washer | Toleranzscheibe | FIB | V-5131H (a/b) |
| 11 | Contre-siège | Disc guide | Gegensitz | 316 | 46653C |
| 12 | Porte-joint | Disc retainer | Dichtungsträger | FTG | V-5012/KC |
| 13 | Joint de siège | Disc | Dichtung | RBR | V-5541H (a/b) |
| 13.1 | Joint de siège (***) | Disc (***) | Dichtung (***) | PET | 21272-01J (b***) |
| 14 | Axe | Stem | Stößel | 303 | C-4047B |
| 15 | Siège | Seat | Sitz | 316 | 46654A |
| 16 | Corps | Body | Gehäuse | FD4 | (**) |
| 17 | Ressort | Spring | Feder | 302 | C-9516A |
| 20 | Joint torique | O-ring | O-Ring | RBR | 00812J (a/b) |
| 22 | Vis (12x) | Screw (12x) | Schraube (12x) | 303 | 67972-25H |
| 23 | Joint torique | O-ring | O-Ring | RBR | 00869J |
| 25 | Bouchon | Plug | Stopfen | 316 | BGT6001 |
| 29 | Rondelle plate | Washer | Unterlegscheibe | 304 | 67756-04 |

(**) Voir / See / Siehe HYT016F

(***) Recommandé si $\Delta P > 16$ bar / Recommended if $\Delta P > 16$ bar / Empfohlen wenn $\Delta P > 16$ bar

KC: Revêtement époxy / Standard epoxy coating / Epoxy-Pulverbeschichtung (minimum 250 μ m)

KCO: KC + Visserie en acier inoxydable / Stainless steel bolts / Deckelschrauben aus Edelstahl

KCS: KC + Siège et contre-siège en acier inoxydable / Stainless steel seat and guide / Sitz und Gegensitz aus Edelstahl

KCOS: KCO + KCS.

► STD: STANDARD

PIECE DE RECHANGE / SPARE PARTS / ERSATZTEILE

| KIT DE REPARATION / REPAIR KIT / REPARATURSATZ | | |
|--|--|------------------|
| (a) | CLA-KIT HYTROL100-01 - GE 300/PN 10 - 16 | 91698-32 |
| (b) | CLA-KIT HYTROL100-01 - GE 300/PN 25 | 🔧 CLA-VAL |

| POS. | DESCRIPTION | DESCRIPTION | BESCHREIBUNG | MAT. | CLA-VAL Nr. |
|------|----------------------|-------------------|-------------------|------|------------------|
| 1 | Bouchon-purgeur | Air release plug | Entlüftungstopfen | 303 | 57576-02 |
| 2 | Bouchon | Cover plug | Stopfen | 316 | BGT6001 |
| 3 | Ecrou | Stud nut | Mutter | 303 | 67818-08J |
| 4 | Goujon | Stud | Gewindebolzen | 303 | V-6896-02A |
| 5 | Palier de chapeau | Cover bearing | Deckellager | 303 | C-8682B |
| 6 | Chapeau | Cover | Deckel | FD4 | 57193-40 |
| 7 | Ecrou d'axe | Stem nut | Stößelmutter | 303 | 25926-01F |
| 8 | Rondelle de membrane | Diaphragm washer | Membranscheibe | FTG | V-5121/KC |
| 9 | Membrane | Diaphragm | Membrane | RBR | V-5544B (a) |
| 9.1 | Membrane (PN 25) | Diaphragm (PN 25) | Membrane (PN 25) | RBR | 1649801G (b) |
| 10 | Cale d'épaisseur | Space washer | Toleranzscheibe | FIB | V-5131H (a/b) |
| 11 | Contre-siège | Disc guide | Gegensitz | 316 | 46653C |
| 12 | Porte-joint | Disc retainer | Dichtungsträger | FTG | V-5012/KC |
| 13 | Joint de siège | Disc | Dichtung | RBR | V-5541H (a/b) |
| 13.1 | Joint de siège (***) | Disc (***) | Dichtung (***) | PET | 21272-01J (b***) |
| 14 | Axe | Stem | Stößel | 303 | C-4047B |
| 15 | Siège | Seat | Sitz | 316 | 46654A |
| 16 | Corps | Body | Gehäuse | FD4 | (**) |
| 17 | Ressort | Spring | Feder | 302 | C-9516A |
| 20 | Joint torique | O-ring | O-Ring | RBR | 00812J (a/b) |
| 22 | Vis (12X) | Screw (12x) | Schraube (12x) | 303 | 67972-25H |
| 23 | Joint torique | O-ring | O-Ring | RBR | 00869J |
| 25 | Bouchon | Plug | Stopfen | 316 | BGT6001 |
| 29 | Rondelle plate | Washer | Unterlegscheibe | 304 | 67756-04 |

(**) Voir / See / Siehe HYT016F

(***) Recommandé si $\Delta P > 16$ bar / Recommended if $\Delta P > 16$ bar / Empfohlen wenn $\Delta P > 16$ bar

KC: Revêtement époxy / Standard epoxy coating / Epoxy-Pulverbeschichtung (minimum 250 μ m)

KCO: KC + Visserie en acier inoxydable / Stainless steel bolts / Deckelschrauben aus Edelstahl

KCS: KC + Siège et contre-siège en acier inoxydable / Stainless steel seat and guide / Sitz und Gegensitz aus Edelstahl

KCOS: KCO + KCS.

► STD: STANDARD

PIECE DE RECHANGE / SPARE PARTS / ERSATZTEILE

| KIT DE REPARATION / REPAIR KIT / REPARATURSATZ | | |
|--|--|------------------|
| (a) | CLA-KIT HYTROL100-01 - GE 300/PN 10 - 16 | 91698-32 |
| (b) | CLA-KIT HYTROL100-01 - GE 300/PN 25 | 🔧 CLA-VAL |

| POS. | DESCRIPTION | DESCRIPTION | BESCHREIBUNG | MAT. | CLA-VAL Nr. |
|------|----------------------|-------------------|-------------------|------|------------------|
| 1 | Bouchon-purgeur | Air release plug | Entlüftungstopfen | 303 | 57576-02 |
| 2 | Bouchon | Cover plug | Stopfen | 316 | BGT6001 |
| 3 | Ecrou | Stud nut | Mutter | 303 | 67818-08J |
| 4 | Goujon | Stud | Gewindebolzen | 303 | V-6896-02A |
| 5 | Palier de chapeau | Cover bearing | Deckellager | 303 | C-8682B |
| 6 | Chapeau | Cover | Deckel | FD4 | 57193-40 |
| 7 | Ecrou d'axe | Stem nut | Stößelmutter | 303 | 25926-01F |
| 8 | Rondelle de membrane | Diaphragm washer | Membranscheibe | FTG | V-5121/KC |
| 9 | Membrane | Diaphragm | Membrane | RBR | V-5544B (a) |
| 9.1 | Membrane (PN 25) | Diaphragm (PN 25) | Membrane (PN 25) | RBR | 1649801G (b) |
| 10 | Cale d'épaisseur | Space washer | Toleranzscheibe | FIB | V-5131H (a/b) |
| 11 | Contre-siège | Disc guide | Gegensitz | 316 | 46653C |
| 12 | Porte-joint | Disc retainer | Dichtungsträger | FTG | V-5012/KC |
| 13 | Joint de siège | Disc | Dichtung | RBR | V-5541H (a/b) |
| 13.1 | Joint de siège (***) | Disc (***) | Dichtung (***) | PET | 21272-01J (b***) |
| 14 | Axe | Stem | Stößel | 303 | C-4047B |
| 15 | Siège | Seat | Sitz | 316 | 46654A |
| 16 | Corps | Body | Gehäuse | FD4 | (**) |
| 17 | Ressort | Spring | Feder | 302 | C-9516A |
| 20 | Joint torique | O-ring | O-Ring | RBR | 00812J (a/b) |
| 22 | Vis (12x) | Screw (12x) | Schraube (12x) | 303 | 67972-25H |
| 23 | Joint torique | O-ring | O-Ring | RBR | 00869J |
| 25 | Bouchon | Plug | Stopfen | 316 | BGT6001 |
| 29 | Rondelle plate | Washer | Unterlegscheibe | 304 | 67756-04 |

(**) Voir / See / Siehe HYT016F

(***) Recommandé si $\Delta P > 16$ bar / Recommended if $\Delta P > 16$ bar / Empfohlen wenn $\Delta P > 16$ bar

KC: Revêtement époxy / Standard epoxy coating / Epoxy-Pulverbeschichtung (minimum 250 μ m)

KCO: KC + Visserie en acier inoxydable / Stainless steel bolts / Deckelschrauben aus Edelstahl

KCS: KC + Siège et contre-siège en acier inoxydable / Stainless steel seat and guide / Sitz und Gegensitz aus Edelstahl

KCOS: KCO + KCS.

► STD: STANDARD

PIECE DE RECHANGE / SPARE PARTS / ERSATZTEILE

| KIT DE REPARATION / REPAIR KIT / REPARATURSATZ | | |
|--|--|------------------|
| (a) | CLA-KIT HYTROL100-01 - GE 400/PN 10 - 16 | 91698-34 |
| (b) | CLA-KIT HYTROL100-01 - GE 400/PN 25 | 🔧 CLA-VAL |

| POS. | DESCRIPTION | DESCRIPTION | BESCHREIBUNG | MAT. | CLA-VAL Nr. |
|------|----------------------|-----------------------|----------------------|------|-------------------|
| 1 | Bouchon-purgeur | Air release plug | Entlüftungstopfen | 303 | 57576-02 |
| 2 | Bouchon | Cover plug | Stopfen | 316 | BGT6001 |
| 3 | Ecrou | Stud nut | Mutter | 303 | 67820-08E |
| 4 | Goujon | Stud | Gewindebolzen | 303 | 37042-03D |
| 5 | Palier de chapeau | Cover bearing | Deckellager | 303 | 57080 |
| 6 | Chapeau | Cover | Deckel | FD4 | 57194-40 |
| 7 | Ecrou d'axe | Stem nut | Stößelmutter | 303 | 57091 |
| 8 | Rondelle de membrane | Diaphragm washer | Membranscheibe | FTG | V-5588/KC |
| 9 | Membrane | Diaphragm | Membrane | RBR | V-5591C (a) |
| 9.1 | Membrane (PN 25) | Diaphragm (PN 25) | Membrane (PN 25) | RBR | 23921-01J (b) |
| 10 | Cale d'épaisseur | Space washer | Toleranzscheibe | FIB | V-5601K (a/b) |
| 11 | Contre-siège | Disc guide | Gegensitz | 316 | 43954-01F |
| 12 | Porte-joint | Disc retainer | Dichtungsträger | FTG | V-5594/KC |
| 13 | Joint de siège | Disc | Dichtung | RBR | V-1689J (a/b) |
| 13.1 | Joint de siège (***) | Disc (***) | Dichtung (***) | PET | V-1689J/KX (b***) |
| 14 | Axe | Stem | Stößel | 303 | 32686J |
| 15 | Siège | Seat | Sitz | 316 | TV5596-01K |
| 16 | Corps | Body | Gehäuse | FD4 | (**) |
| 17 | Ressort | Spring | Feder | 302 | 30104E |
| 18 | Vis de palier (8x) | Screw (8x) | Schraube (8x) | SST | 67605-07B |
| 19 | Joint de palier | Cover bearing gasket | Dichtung | RBR | 00589C |
| 20 | Joint torique | O-ring | O-Ring | RBR | 00876D |
| 22 | Vis (12x) | Screw (12x) | Schraube (12x) | 303 | 67973-26D |
| 21 | Réduction supérieur | Pipe cap | Kappe | 304 | 57008-01 |
| 23 | Joint torique | O-ring | O-Ring | RBR | 00999D |
| 25 | Bouchon | Plug | Stopfen | 316 | BGT6001 |
| 29 | Rondelle plate | Washer | Unterlegscheibe | 304 | 67757-04 |
| 30 | Support guide | Housing cover bearing | Deckellagerhalterung | FD4 | V-6700-01/KC |

(**) Voir / See / Siehe HYT016F

(***) Recommandé si $\Delta P > 16$ bar / Recommended if $\Delta P > 16$ bar / Empfohlen wenn $\Delta P > 16$ bar

KC: Revêtement époxy / Standard epoxy coating / Epoxy-Pulverbeschichtung (minimum 250 μ m)

KCO: KC + Visserie en acier inoxydable / Stainless steel bolts / Deckelschrauben aus Edelstahl

KCS: KC + Siège et contre-siège en acier inoxydable / Stainless steel seat and guide / Sitz und Gegensitz aus Edelstahl

KCOS: KCO + KCS.

► STD: STANDARD

PIECE DE RECHANGE / SPARE PARTS / ERSATZTEILE

| KIT DE REPARATION / REPAIR KIT / REPARATURSATZ | | |
|--|--|------------------|
| (a) | CLA-KIT HYTROL100-01 - GE 400/PN 10 - 16 | 91698-34 |
| (b) | CLA-KIT HYTROL100-01 - GE 400/PN 25 | 🔧 CLA-VAL |

| POS. | DESCRIPTION | DESCRIPTION | BESCHREIBUNG | MAT. | CLA-VAL Nr. |
|------|----------------------|-----------------------|----------------------|------|-------------------|
| 1 | Bouchon-purgeur | Air release plug | Entlüftungstopfen | 303 | 57576-02 |
| 2 | Bouchon | Cover plug | Stopfen | 316 | BGT6001 |
| 3 | Ecrou | Stud nut | Mutter | 303 | 67820-08E |
| 4 | Goujon | Stud | Gewindebolzen | 303 | 37042-03D |
| 5 | Palier de chapeau | Cover bearing | Deckellager | 303 | 57080 |
| 6 | Chapeau | Cover | Deckel | FD4 | 57194-40 |
| 7 | Ecrou d'axe | Stem nut | Stößelmutter | 303 | 57091 |
| 8 | Rondelle de membrane | Diaphragm washer | Membranscheibe | FTG | V-5588/KC |
| 9 | Membrane | Diaphragm | Membrane | RBR | V-5591C (a) |
| 9.1 | Membrane (PN 25) | Diaphragm (PN 25) | Membrane (PN 25) | RBR | 23921-01J (b) |
| 10 | Cale d'épaisseur | Space washer | Toleranzscheibe | FIB | V-5601K (a/b) |
| 11 | Contre-siège | Disc guide | Gegensitz | 316 | 43954-01F |
| 12 | Porte-joint | Disc retainer | Dichtungsträger | FTG | V-5594/KC |
| 13 | Joint de siège | Disc | Dichtung | RBR | V-1689J (a/b) |
| 13.1 | Joint de siège (***) | Disc (***) | Dichtung (***) | PET | V-1689J/KX (b***) |
| 14 | Axe | Stem | Stößel | 303 | 32686J |
| 15 | Siège | Seat | Sitz | 316 | TV5596-01K |
| 16 | Corps | Body | Gehäuse | FD4 | (**) |
| 17 | Ressort | Spring | Feder | 302 | 30104E |
| 18 | Vis de palier (8x) | Screw (8x) | Schraube (8x) | SST | 67605-07B |
| 19 | Joint de palier | Cover bearing gasket | Dichtung | RBR | 00589C |
| 20 | Joint torique | O-ring | O-Ring | RBR | 00876D |
| 22 | Vis (12x) | Screw (12x) | Schraube (12x) | 303 | 67973-26D |
| 21 | Réduction supérieur | Pipe cap | Kappe | 304 | 57008-01 |
| 23 | Joint torique | O-ring | O-Ring | RBR | 00999D |
| 25 | Bouchon | Plug | Stopfen | 316 | BGT6001 |
| 29 | Rondelle plate | Washer | Unterlegscheibe | 304 | 67757-04 |
| 30 | Support guide | Housing cover bearing | Deckellagerhalterung | FD4 | V-6700-01/KC |

(**) Voir / See / Siehe HYT016F

(***) Recommandé si $\Delta P > 16$ bar / Recommended if $\Delta P > 16$ bar / Empfohlen wenn $\Delta P > 16$ bar

KC: Revêtement époxy / Standard epoxy coating / Epoxy-Pulverbeschichtung (minimum 250 μ m)

KCO: KC + Visserie en acier inoxydable / Stainless steel bolts / Deckelschrauben aus Edelstahl

KCS: KC + Siège et contre-siège en acier inoxydable / Stainless steel seat and guide / Sitz und Gegensitz aus Edelstahl

KCOS: KCO + KCS.

The CLA-VAL CDS-6A Altitude Pilot Control is a spring-loaded, 3-way, diaphragm-actuated control that senses pressure in the reservoir.

When the reservoir pressure (liquid level) is lower than the set point of control, ports 1 and D are interconnected. This relieves main valve cover pressure to atmosphere and the main valve opens to fill the reservoir. Reservoir sensing pressure increases as the liquid level rises in the reservoir. When reservoir pressure increases to the set point of control, control shifts, interconnecting ports S and 1. This pressurizes the main valve cover and the main valve closes.

Adjustment:

turn the spring adjusting nut (4) clockwise to increase the liquid level shutoff point.

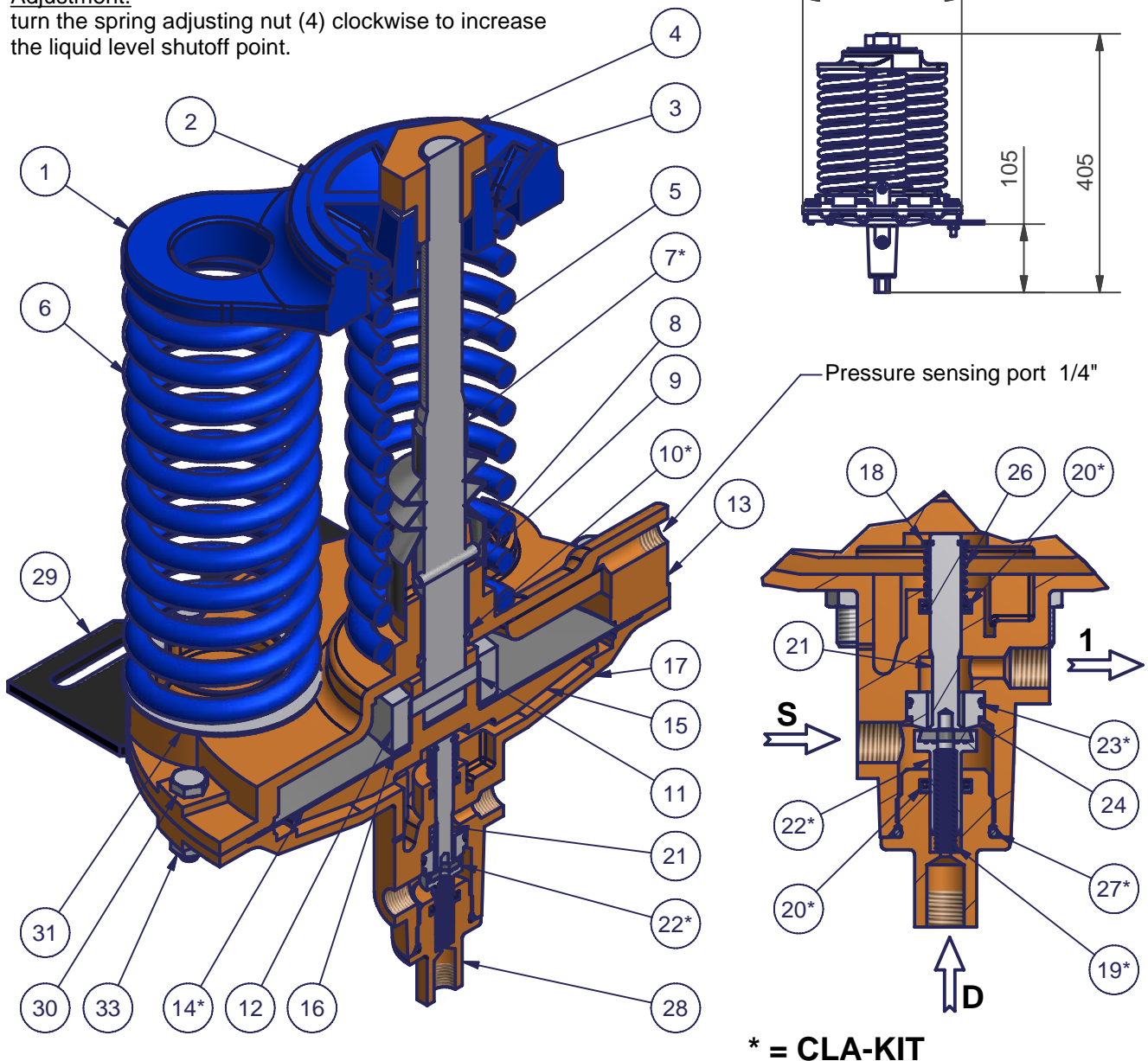

Adjustment ranges

- 0,1 - 1,2 bar (1 Spring)
- 1,2 - 2,4 bar (2 Springs)
- 2,4 - 3,6 bar (3 Springs)
- 3,6 - 4,8 bar (4 Springs)
- 4,8 - 6,0 bar (5 Springs)

CLA-VAL No.

- 203547-01K
- 203547-02J
- 203547-03H
- 203547-04G
- 203547-05F

Information

- ✓ Spare parts : CDS601LT

► STD: Standard

PIECE DE RECHANGE / SPARE PARTS / ERSATZTEILE

| KIT DE REPARATION / REPAIR KIT / REPARATURSATZ | | |
|--|-------------------------|---------------|
| (a) | CLA-KIT CDS-6A Standard | *CKCD6-STD-02 |

| POS. | DESCRIPTION | DESCRIPTION | BESCHREIBUNG | MAT. | CLA-VAL Nr. |
|------|-----------------------|-------------------------------|--------------------------|------|----------------|
| 1 | Etrier (4-5 ressorts) | Retainer spring (4-5 springs) | Federhalter (4-5 Federn) | FTG | 29331-01E |
| 1.1 | Etrier (2-3 ressorts) | Retainer spring (2-3 springs) | Federhalter (2-3 Federn) | FTG | 29332-01C |
| 2 | Guide-ressort | Spring guide | Führung | IEC | 2933401J |
| 3 | Rondelle d'appui | Washer thrust | Auflag-Scheibe | NYL | 76783A |
| 4 | Ecrou de réglage | Nut adjusting | Regel-Mutter | NBS | 1077601B |
| 5 | Axe | Stem | Stößel | 303 | 2933301A |
| 6 | Ressort | Spring | Feder | CEC | 2933502H |
| 7 | Soufflet | Bellows | Faltenbalg | NEO | 10275-01E (a) |
| 8 | Vis sans tête | Set screw | Gewindestifte | SST | 6764928F |
| 9 | Palier lisse | Bearing | Gleitlager | AK | 79904K |
| 10 | Joint torique | O-ring | O-Ring | TNB | 01068G (a) |
| 11 | Goupille | Pin | Stift | 303 | 6674601H |
| 12 | Ecrou de membrane | Nut | Membrane-Mutter | 303 | 20039701G |
| 13 | Couvercle supérieur | Cover upper | Deckel oben | BRZ | 2932601E |
| 14 | Membrane | Diaphragm | Membrane | RBR | 23339-01H (a) |
| 15 | Rondelle de membrane | Diaphragm washer | Membranscheibe | BRZ | 2932701C |
| 16 | Rondelle d'appui | Washer diaphragm nut | Auflage-Scheibe | SST | 7198837C |
| 17 | Couvercle inférieur | Cover lower | Deckel unten | BRZ | 20354901H |
| 18 | Circlip | Ring retainer | Sicherungsring | SST | 68185-11F (a) |
| 19 | Ressort | Spring | Feder | 302 | 90292-10D (a) |
| 20 | Manchette | Gasket | Nutringmanschette | RBR | 203154-01D (a) |
| 21 | Tige inférieure | Stem lower | Untere Spindel | 303 | 66668F |
| 22 | Clapet | Poppet assembly | Klappe | SR | 66675A (a) |
| 23 | Joint torique | O-ring | O-Ring | RBR | 00719F (a) |
| 24 | Siège | Seat | Sitz | 303 | 2932901J |
| 25 | Filtre | Strainer | Filter | LTO | 66753F (a) |
| 26 | Ressort | Spring | Feder | 303 | 79092D (a) |
| 27 | Joint torique | O-ring | O-Ring | RBR | 00540F (a) |
| 28 | Guide de clapet | Guide poppet | Klappen-Führung | BRZ | 20357501E |
| 29 | Plaque | Plate | Platte | CEC | 2933601D |
| 30 | Vis (10x) | Screw (10x) | Schraube (10x) | SST | 6760408C |
| 31 | Rondelle d'appui | Washer | Scheibe | SST | 71988-41E |
| 32 | Vis (2x) | Screw (2x) | Schraube (2x) | SST | 6760412E |
| 33 | Ecrou (12x) | Nut (12x) | Mutter (12x) | SST | 6779907C |

| TYPE CDS-6A/STD | CLA-VAL Nr. |
|-----------------|-------------|
| 0,1 - 1,2 bar | 203547-01K |
| 1,2 - 2,4 bar | 203547-02J |
| 2,4 - 3,6 bar | 203547-03H |
| 3,6 - 4,8 bar | 203547-04G |
| 4,8 - 6,0 bar | 203547-05F |

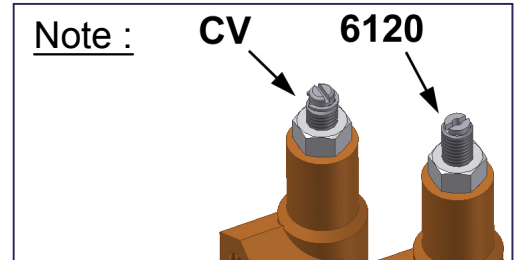
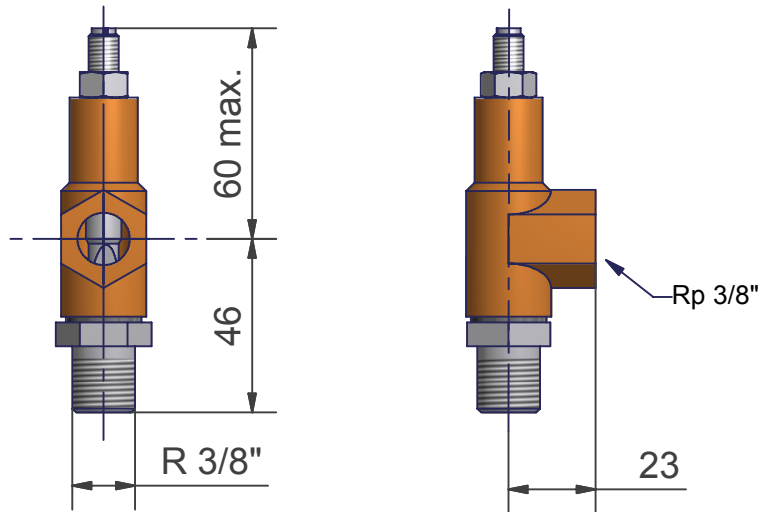

* = CLA-KIT

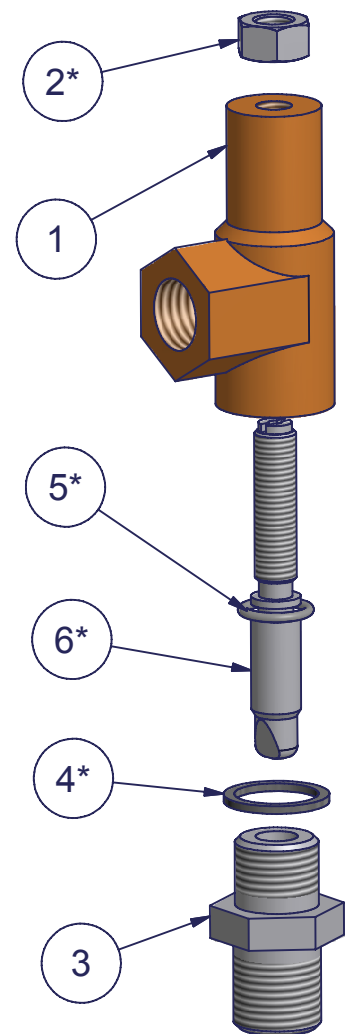
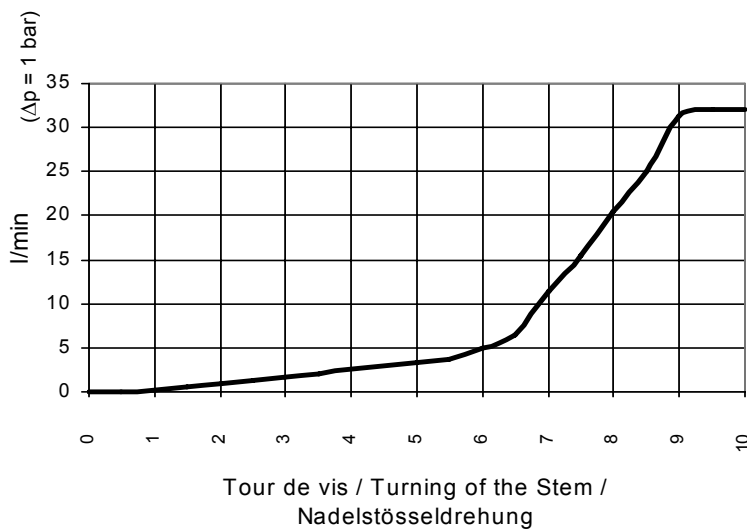

| POS | DESCRIPTION | DESCRIPTION | BESCHREIBUNG |
|-----|---------------|-------------|--------------|
| 1 | Corps | Body | Gehäuse |
| 2 | Ecrou | Nut | Mutter |
| 3 | Siège | Seat | Sitz |
| 4 | Joint | Gasket | Dichtung |
| 5 | Joint torique | O-ring | O-ring |
| 6 | Pointeau | Stem | Nadelstössel |

● Information

- ✓ 6120 Standard 612001LT
- ✓ 6120/WWS 612003LT
- ✓ 6120/IND 612004LT
- ✓ 6120/OFS 612005LT
- ✓ 6120/SWS 612002LT
- ✓ 6120/AF 612008LT



CLA-VAL 6120

Robinet à pointeau - Needle Valve - Nadelventil
PN 10 - 16 - 25

► STD: Standard

PIECE DE RECHANGE / SPARE PARTS / ERSATZTEILE

| KIT DE REPARATION / REPAIR KIT / REPARATURSATZ | | |
|--|-----------------------|----------------|
| (a) | CLA-KIT 6120 Standard | *CK6120-STD-01 |

| POS. | DESCRIPTION | DESCRIPTION | BESCHREIBUNG | MAT. | CLA-VAL Nr. |
|------|---------------|-------------|--------------|------|---------------|
| 1 | Corps | Body | Gehäuse | BRZ | 57644 |
| 2 | Ecrou | Nut | Mutter | 303 | 67800-06A (a) |
| 3 | Siège | Seat | Sitz | 303 | 57806-01 |
| 4 | Joint | Gasket | Dichtung | FIB | 30022J (a) |
| 5 | Joint torique | O-ring | O-Ring | VIT | 00927E (a) |
| 6 | Pointeau | Stem | Nadelstößel | 316L | 57864 (a) |

| TYPE 6120/STD | CLA-VAL Nr. |
|---------------|-------------|
| 6120 | RPT3041 |

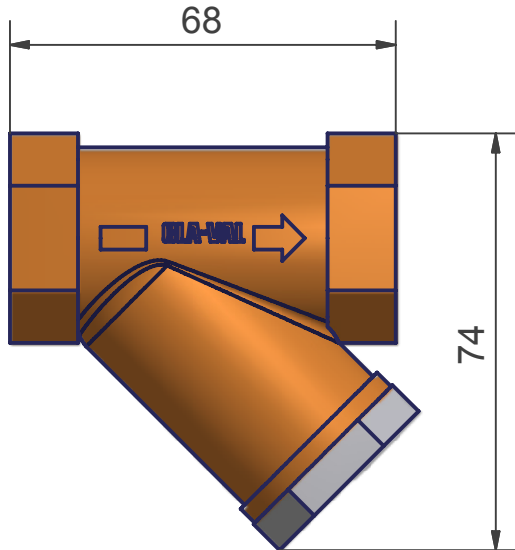

Filtere X43

Ce filtre empêche tout corps étranger de pénétrer dans le circuit d'asservissement.

Il est recommandé de nettoyer périodiquement la cartouche du filtre.

Strainer X43

The strainer is installed in the pilot supply line to protect the pilot system from foreign particles. The strainer screen must be cleaned periodically.

Filter X43

Der Filter verhindert das Eindringen von Fremdkörpern ins Steuersystem.

Das Sieb des Filters muss von Zeit zu Zeit gereinigt werden.

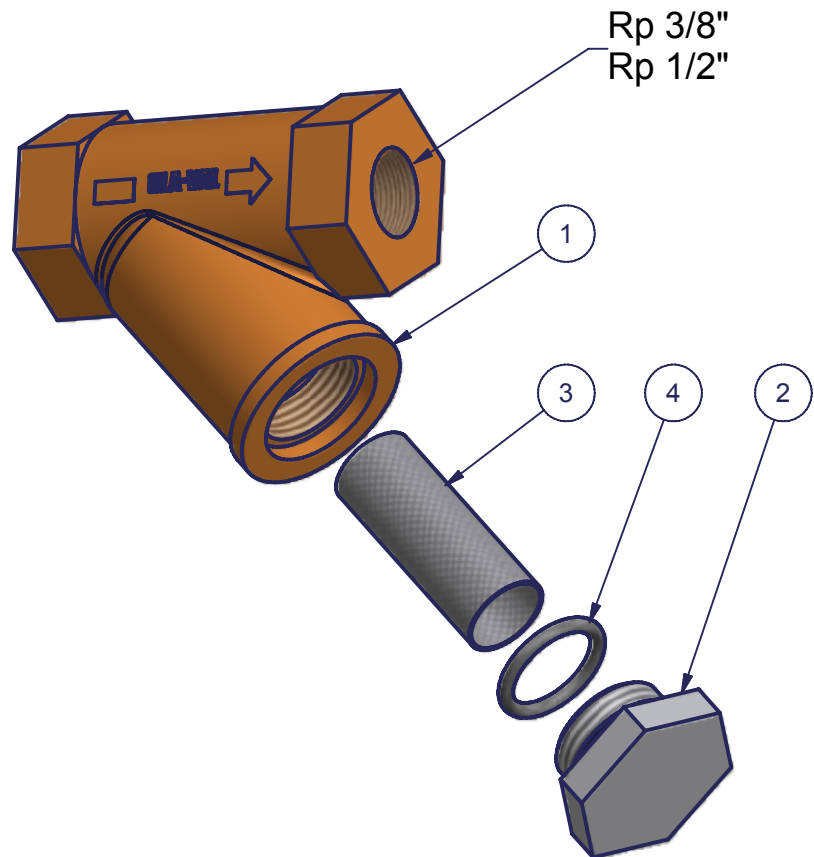

| POS | Description | Description | Description |
|-----|-----------------|---------------|---------------|
| 1 | Corps | Body | Gehäuse |
| 2 | Guide-cartouche | Strainer plug | Filter Zapfen |
| 3 | Cartouche | Screen | Sieb |
| 4 | Joint torique | O-ring | O-Ring |



CLA-VAL X43

Filtre - Strainer - Filter
PN 10 - 16 - 25

► STD: Standard

PIECE DE RECHANGE / SPARE PARTS / ERSATZTEILE

| KIT DE REPARATION / REPAIR KIT / REPARATURSATZ | | |
|--|--|---------------|
| (a) | CLA-KIT X43 Standard (Cartouche, Screen, Sieb 0,2) | *CKX43-STD-01 |
| (b) | CLA-KIT X43 Standard (Cartouche, Screen, Sieb 1,6) | - |

| POS. | DESCRIPTION | DESCRIPTION | BESCHREIBUNG | MAT. | CLA-VAL Nr. |
|------|-------------------|-------------|--------------|------|--------------|
| 1 | Corps 3/8" | Body 3/8" | Gehäuse 3/8" | BRZ | 57296 |
| 1.1 | Corps 1/2" | Body 1/2" | Gehäuse 1/2" | BRZ | 57296-12 |
| 2 | Bouchon supérieur | Plug | Zapfen | 303 | 57334 |
| 3 | Cartouche 0,2 | Screen 0,2 | Sieb 0,2 | MO4 | 68373A (a) |
| 3.1 | Cartouche 1,6 | Screen 1,6 | Sieb 1,6 | 316 | 57332 (b) |
| 4 | Joint torique | O-ring | O-Ring | RBR | 00751J (a/b) |

| TYPE X43/STD | CLA-VAL Nr. | |
|--------------|-------------|-----|
| Rp 1/2" | FLB4300-03 | 0,2 |
| Rp 1/2" | FLB4300-07 | 1,6 |
| Rp 3/8" | FLB4300-01 | 0,2 |
| Rp 3/8" | FLB4300-05 | 1,6 |

Robinet de barrage à bille

Corps laiton nickelé ou inox, mécanisme interne en inox

Isolation Ball Valve

Stainless steel or nickel plated body, stainless steel 303 trim

Kugelhahn

Gehäuse aus vernickeltem Messing oder Edelstahl, Innenteile aus Edelstahl

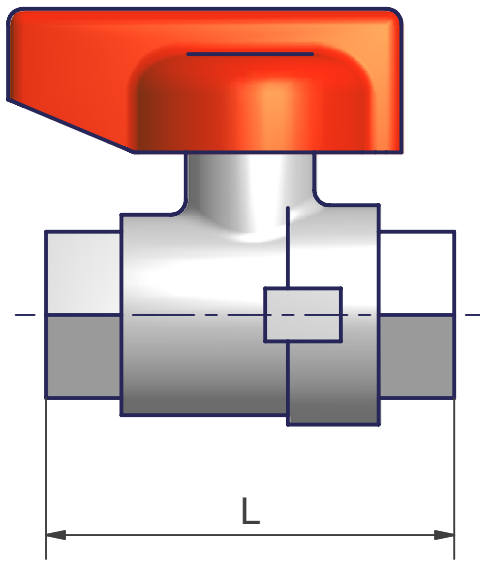

| Rp | 3/8" | 1/2" | 3/4" | 1" |
|----|------|------|------|-----|
| L | 49 | 61 | 70 | 84 |
| A | 85 | 85 | 105 | 105 |

Type : M

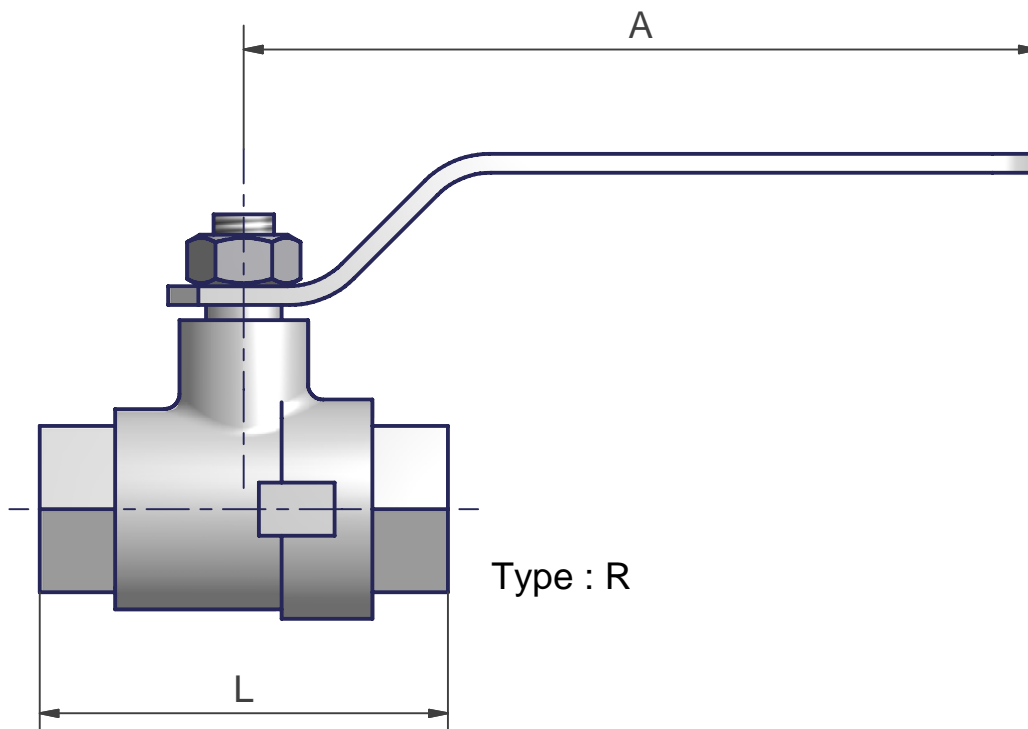

Type : R



CLA-VAL Form







Valve Specification



| | |
|-------------------|-------|
| Client / Contact: | |
| Ref.: | Date: |





| HYDRAULIC PARAMETERS | | | |
|----------------------|---|--|-----|
| A | Maximum flow rate (Q peak consumption) | | l/s |
| | Upstream dynamic pressure (at Q peak) | | bar |
| | Minimum flow rate (Q night) | | l/s |
| | Upstream static pressure (at Q night) | | bar |
| | Intermittent max. flow rate (Q fire) | | l/s |
| B | Back-pressure (water level in reservoir) | | m |

| SETTING | | | |
|----------|---|--|-----|
| C | Flow rate | | l/s |
| D | Surge flow rate (surge flow closing) | | l/s |
| E | Downstream pressure | | bar |
| F | Surge pressure rate (surge pressure closing) | | bar |
| G | Upstream pressure or relief pressure | | bar |
| I | $\Delta P > 20$ bar | <input type="checkbox"/> Yes => <input type="checkbox"/> No | |

| J | SCHEMATIC |
|----------|-----------|
| | |

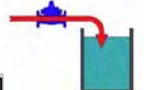
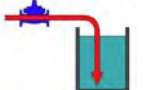
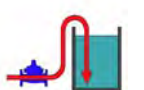
| CLA-VAL MAIN VALVE | | | | | | | | | | | | | | | | | |
|--------------------|--------|---|---|---|---|---|---|-----------------------------|--------------------------|--------------------------------|----|------------------------------|----|----|----|----|----|
| K | | <input type="checkbox"/> NGE | | <input type="checkbox"/> NGE-316 | | <input type="checkbox"/> GE | | <input type="checkbox"/> AE | | <input type="checkbox"/> TYTAN | | <input type="checkbox"/> TDV | | | | | |
| | |  |  |  |  |  |  | | | | | | | | | | |
| DN | Rp | DN | Rp | DN | Rp | DN | Rp | DN | Rp | DN | Rp | DN | Rp | DN | Rp | DN | Rp |
| 32 | 1 1/4" | | | | | <input type="checkbox"/> | <input type="checkbox"/> | <input type="checkbox"/> | <input type="checkbox"/> | | | | | | | | |
| 40 | 1 1/2" | | | <input type="checkbox"/> | | <input type="checkbox"/> | <input type="checkbox"/> | <input type="checkbox"/> | <input type="checkbox"/> | | | | | | | | |
| 50 | 2" | <input type="checkbox"/> | | <input type="checkbox"/> | | <input type="checkbox"/> | <input type="checkbox"/> | <input type="checkbox"/> | <input type="checkbox"/> | | | | | | | | |
| 65 | 2 1/2" | <input type="checkbox"/> | | <input type="checkbox"/> | | <input type="checkbox"/> | <input type="checkbox"/> | <input type="checkbox"/> | <input type="checkbox"/> | | | | | | | | |
| 80 | 3" | <input type="checkbox"/> | | <input type="checkbox"/> | | <input type="checkbox"/> | <input type="checkbox"/> | <input type="checkbox"/> | <input type="checkbox"/> | | | <input type="checkbox"/> | | | | | |
| 100 | | <input type="checkbox"/> | | <input type="checkbox"/> | | <input type="checkbox"/> | | <input type="checkbox"/> | | | | <input type="checkbox"/> | | | | | |
| 125 | | <input type="checkbox"/> | | <input type="checkbox"/> | | | | | | | | <input type="checkbox"/> | | | | | |
| 150 | | <input type="checkbox"/> | | <input type="checkbox"/> | | <input type="checkbox"/> | | <input type="checkbox"/> | | | | <input type="checkbox"/> | | | | | |
| 200 | | <input type="checkbox"/> | | <input type="checkbox"/> | | <input type="checkbox"/> | | <input type="checkbox"/> | | | | <input type="checkbox"/> | | | | | |
| 250 | | <input type="checkbox"/> | | | | <input type="checkbox"/> | | <input type="checkbox"/> | | | | <input type="checkbox"/> | | | | | |
| 300 | | <input type="checkbox"/> | | | | <input type="checkbox"/> | | <input type="checkbox"/> | | | | | | | | | |
| 350 | | <input type="checkbox"/> | | | | <input type="checkbox"/> | | <input type="checkbox"/> | | | | | | | | | |
| 400 | | <input type="checkbox"/> | | | | <input type="checkbox"/> | | <input type="checkbox"/> | | | | | | | | | |
| 450 | | <input type="checkbox"/> | | | | | | | | | | | | | | | |
| 500 | | <input type="checkbox"/> | | | | | | | | | | | | | | | |
| 600 | | <input type="checkbox"/> | | | | | | | | | | | | | | | |
| S 600 | | | | | | | | | | | | <input type="checkbox"/> | | | | | |
| S 700 | | | | | | | | | | | | <input type="checkbox"/> | | | | | |
| S 800 | | | | | | | | | | | | <input type="checkbox"/> | | | | | |
| M 900 | | | | | | | | | | | | <input type="checkbox"/> | | | | | |
| M 1000 | | | | | | | | | | | | <input type="checkbox"/> | | | | | |
| L 900 | | | | | | | | | | | | <input type="checkbox"/> | | | | | |
| L 1000 | | | | | | | | | | | | <input type="checkbox"/> | | | | | |
| L 1200 | | | | | | | | | | | | <input type="checkbox"/> | | | | | |

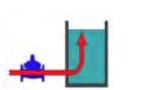
| VALVE INSTALLATION | | | | | |
|--------------------|--|--|--|--|--|
| L | <input type="checkbox"/>  | <input type="checkbox"/>  | <input type="checkbox"/>  | <input type="checkbox"/>  | <input type="checkbox"/>  |

| LEVEL CONTROL INSTALLATION | | | | | | |
|----------------------------|--|--|--|---|--|--|
| M | <input type="checkbox"/>  | <input type="checkbox"/>  | <input type="checkbox"/>  | <input type="checkbox"/>  | <input type="checkbox"/>  | <input type="checkbox"/>  |
| | Reservoir <input type="checkbox"/> Open |  | Reservoir <input type="checkbox"/> Closed |  | <input type="checkbox"/> Constant level | <input type="checkbox"/> 2 levels (high and low) |
| | | | | | <input type="checkbox"/> 1 high level | <input type="checkbox"/> 1 low level |

| ELECTRICAL SPECIFICATIONS | | | | | | | | |
|---------------------------|---------------------------------------|--------------------------------|---|---------------------------------|---|-------------------------------|-------------------------------|---------------------------------|
| N | When switched off, the main valve is: | | (Type D) <input type="checkbox"/> Opened | | (Type E) <input type="checkbox"/> Closed | | Notes: | |
| | | Standard | | | | | | |
| | Voltage | <input type="checkbox"/> 220 V | <input type="checkbox"/> 110 V | <input type="checkbox"/> 48 V | <input type="checkbox"/> 36 V | <input type="checkbox"/> 24 V | <input type="checkbox"/> 24 V | <input type="checkbox"/> Other: |
| | Frequency | <input type="checkbox"/> 50 Hz | <input type="checkbox"/> VDC | <input type="checkbox"/> Other: | | | | |
| Mode | <input type="checkbox"/> Mono-stable | | <input type="checkbox"/> Bi-stable | | | | | |



| O STANDARD CLA-VAL VALVES: Catalog and Website | | | | | | | | | | | |
|--|-------|-----|-----------------------------------|-------|-----|-----------------------------------|-------|-----|----------------------------------|-------|-----|
| Downstream Control | | | Upstream Control | | | Flow Rate Control | | | Level Control | | |
| <input type="checkbox"/> 90-01 | AEL | OIO | <input type="checkbox"/> 50-01 | AGL | OI- | <input type="checkbox"/> 40-01 | ACL | OI- | <input type="checkbox"/> 100-CF9 | ABLM | OI- |
| <input type="checkbox"/> 90-CF9 | ABELM | OIO | <input type="checkbox"/> 50-CF9 | ABGLM | OI- | <input type="checkbox"/> 40-CF9 | ABCLM | OI- | <input type="checkbox"/> 113-CF9 | ABLM | OI- |
| <input type="checkbox"/> 91-01 | AEL | OIO | <input type="checkbox"/> 51-01 | AGL | OI- | <input type="checkbox"/> 41-01 | ACL | OI- | <input type="checkbox"/> 427-01 | ABLM | OI- |
| <input type="checkbox"/> 93E/D-01 | AELN | OIO | <input type="checkbox"/> 58E/D-01 | AGLN | OI- | <input type="checkbox"/> 43E/D-01 | ACLN | OI- | <input type="checkbox"/> 429-01 | ABLMN | OI- |
| <input type="checkbox"/> 92-01 | AEGL | OIO | <input type="checkbox"/> 52-03 | AEGL | OI- | <input type="checkbox"/> 45-01 | ACGL | OI- | <input type="checkbox"/> 208-01 | ABLM | OI- |
| <input type="checkbox"/> 92-02 | AEGL | OIO | <input type="checkbox"/> 52-03R | AEGL | OI- | <input type="checkbox"/> 49-01 | ACEL | OIO | <input type="checkbox"/> 210-01 | ABLM | OI- |
| <input type="checkbox"/> 94-01 | AEFL | OIO | | | | | | | <input type="checkbox"/> 210-16 | ABLM | OI- |
| <input type="checkbox"/> 94-16 | AEFGL | OIO | | | | | | | <input type="checkbox"/> 210-21 | ABCLM | OI- |
| | | | | | | | | | <input type="checkbox"/> 210-31 | ABLM | OI- |
| | | | | | | | | | <input type="checkbox"/> 210-66 | ABGLM | OI- |

| Pump Control | | | Network Protection | | | Electrical Control | | |
|-----------------------------------|------|-----|--------------------------------|-----|-----|------------------------------------|-----|-----|
| <input type="checkbox"/> 60-31/02 | AEGL | OI- | <input type="checkbox"/> 81-01 | AL | OI- | <input type="checkbox"/> 136E/D-01 | ALN | OI- |
| <input type="checkbox"/> 60-31/72 | AEGL | OI- | <input type="checkbox"/> 81-02 | AL | OI- | <input type="checkbox"/> 136E/D-03 | ALN | OI- |
| <input type="checkbox"/> 60-81 | AEGL | OI- | <input type="checkbox"/> 85-01 | ADL | OI- | <input type="checkbox"/> 136-07 | ALN | OI- |
| | | | <input type="checkbox"/> 85-03 | ADL | OI- | <input type="checkbox"/> 136-38 | ALN | OI- |
| | | | <input type="checkbox"/> 85-18 | AFL | OI- | | | |

Hydraulic parameters
 And required settings
 Standard Equipment:
 Upstream manometer → O
 Position indicator X101 → I
 Downstream manometer → O

| ECO | | | PLC | | | PCM | | | MVE | | |
|---------------------------------|-------|-----|--|-------|-----|---------------------------------|------|-----|--|------|-----|
| <input type="checkbox"/> 32-07 | ALN | OI- | <input type="checkbox"/> 137/38/39-001 | AEGLN | OI- | <input type="checkbox"/> 100-01 | ABLM | OI- | <input type="checkbox"/> 137/38/39-500 | ACLN | OI- |
| <input type="checkbox"/> 100-31 | ABLMN | OI- | <input type="checkbox"/> 137/38/39-400 | ACLN | OI- | <input type="checkbox"/> 90-01 | AEL | OIO | | | |
| <input type="checkbox"/> 136-01 | ALN | OI- | <input type="checkbox"/> 137/38/39-402 | ACLN | OI- | <input type="checkbox"/> 50-01 | AGL | OI- | | | |
| <input type="checkbox"/> 417-07 | ABLMN | OI- | <input type="checkbox"/> 137/38/39-201 | ABLMN | OI- | <input type="checkbox"/> 40-01 | ACL | OI- | | | |
| | | | <input type="checkbox"/> 137/38/39-100 | ABLMN | OIO | | OI- | | | | |

| P OPTIONAL FEATURES | | | | | | | | | | | |
|-----------------------------|---|--|--|-----------------------------|---|--|--|-----------------------------|---|--|--|
| <input type="checkbox"/> A | Flow Clean Strainer (X46A) | | | <input type="checkbox"/> O | Nylon Pipe Dia. 6/3 mm (STD with SERIE 40) | | | <input type="checkbox"/> W2 | Opening Limiter (Level Control) | | |
| <input type="checkbox"/> C | One-Way Flow Control (Closing Speed) (CV) | | | <input type="checkbox"/> P | 2-Way Pressure Cock (STD with SERIE 40) | | | <input type="checkbox"/> Y | High Capacity Strainer (X43/80-EP) | | |
| <input type="checkbox"/> F | Remote Pressure Sensing | | | <input type="checkbox"/> P1 | Isolation Ball Valve | | | <input type="checkbox"/> Y2 | Double Strainer (2 x X43) | | |
| <input type="checkbox"/> H | Solenoid Drain to Atmosphere | | | <input type="checkbox"/> S | One-Way Flow Control (Opening Speed) (CV) | | | <input type="checkbox"/> Y3 | Double Strainer (1 x X43/80-EP + 1 x X43) | | |
| <input type="checkbox"/> H1 | Solenoid Drain to Main Valve Outlet | | | <input type="checkbox"/> T | Delayed Opening (Serie 210, 2 Levels) | | | <input type="checkbox"/> Y4 | Double High Capacity Filter (2 x X43/80-EP) | | |
| <input type="checkbox"/> M | Manual Command (Drain to Main Valve Outlet) | | | <input type="checkbox"/> V | Independant Opening / Closing Speed Setting (VRE) | | | | | | |
| <input type="checkbox"/> M1 | Manual Command (Drain to Atmosphere) | | | <input type="checkbox"/> W1 | Anti Freeze Feature (Level Control) | | | | | | |

| Q ACCESSORIES | | | | | | | | | | | |
|--|--|--|--|--|--|------------------------------|--|---|--|--|--|
| Position Indicator X101 | | | | | | Note, preset: | | | | | |
| | | | | | | <input type="checkbox"/> No | | | | | |
| Mechanical Lift Limiter X102-A | | | | | | <input type="checkbox"/> Yes | | | | | |
| Hydraulic Lift Limiter X102-F | | | | | | <input type="checkbox"/> Yes | | | | | |
| Magnetic Switch Assembly X105-M (1 A max) | | | | | | <input type="checkbox"/> Yes | | <input type="checkbox"/> 1 contact (X105-MCW) | | <input type="checkbox"/> 2 contacts (X105-M2W) | |
| Electronic Valve Position Indicator e-Lift | | | | | | <input type="checkbox"/> Yes | | <input type="checkbox"/> 2 alarms | | <input type="checkbox"/> 4 alarms | |
| Upstream Manometer | | | | | | <input type="checkbox"/> No | | <input type="checkbox"/> 0-16 bar (STD) | | <input type="checkbox"/> 0-10 bar | |
| Downstream Manometer | | | | | | <input type="checkbox"/> No | | <input type="checkbox"/> 0-16 bar (STD) | | <input type="checkbox"/> 0-10 bar | |
| Upstream manometer connector | | | | | | <input type="checkbox"/> No | | <input type="checkbox"/> CSA-12 (STD) | | <input type="checkbox"/> CSA-11 | |
| Downstream manometer connector | | | | | | <input type="checkbox"/> No | | <input type="checkbox"/> CSA-12 (STD) | | <input type="checkbox"/> CSA-11 | |
| Other: | | | | | | <input type="checkbox"/> | | | | | |

| FLANGES DN ≤ 600 | | | Standard Test CLA-VAL IT123 | | |
|--------------------------|-------------------------|--|--|---|---|
| R | Flange drilling (CLASS) | | Pressure (bar) | Test pressure (bar) | |
| | | | PFA | PT1 | PT2 |
| <input type="checkbox"/> | ISO PN 10 | | 10 bar | 15 bar | 11 bar |
| <input type="checkbox"/> | ISO PN 16 | | 16 bar | 25 bar | 18 bar |
| <input type="checkbox"/> | ISO PN 25 | | 25 bar | 38 bar | 28 bar |
| <input type="checkbox"/> | ISO PN 40 | | 40 bar | 44 bar | 44 bar |
| <input type="checkbox"/> | ANSI 125 | | 175 psi (12 bar) | 18 bar | 14 bar |
| <input type="checkbox"/> | ANSI 150 | | 250 psi (17 bar) | 26 bar | 19 bar |
| <input type="checkbox"/> | ANSI 250 | | 400 psi (28 bar) | 42 bar | 31 bar |
| <input type="checkbox"/> | ANSI 300 | | 400 psi (28 bar) | 42 bar | 31 bar |
| On request: | | | <input type="checkbox"/> CE Test IT122 | <input type="checkbox"/> Air Test IT125 | <input type="checkbox"/> TYTAN Test IT126 |

Definitions:

PFA: Allowable operating pressure: Maximum hydrostatic pressure that a component is capable of withstanding continuously in service.

PT1: Test Pressure 1: Pressure test used for: ← Shell pressure test.

PT2: Test Pressure 2: Pressure test used for: ↑ Pilot system pressure test.

→ Seat tightness test.

↓ Diaphragm tightness test.

| TYPE OF FLUID AND CLA-VAL STANDARDS | | | | |
|-------------------------------------|---|--|---|---|
| S | <input type="checkbox"/> Drinking water | <input type="checkbox"/> Industrial water | <input type="checkbox"/> Brackish water | Temperature: |
| | <input type="checkbox"/> Irrigation water | <input type="checkbox"/> Demineralised water | <input type="checkbox"/> Sea water | <input type="checkbox"/> Material in suspension |

| CLA-VAL STANDARDS FOR MATERIAL | | Main valve | Pilot circuit |
|--|--|--|---|
| T | <ul style="list-style-type: none"> • Drinking water (PN 10-25) • Irrigation water • Active Cl < 0,30 mg/l • Total salts < 1,0 g/l <input type="checkbox"/> STD (Standard) | NGE / GE / AE / EAE / TDV <ul style="list-style-type: none"> • Body: ductile iron* • Mechanism**: SS 303 • Bolting: SS 303 | <ul style="list-style-type: none"> • Body: bronze • Mechanism: SS 303 |
| | <ul style="list-style-type: none"> • Drinking water (PN 40+) • Industrial water • Active Cl < 0,50 mg/l • Total salts. < 5,0 g/l <input type="checkbox"/> WWS (Waterworks) | NGE-316 / Roll Seal <ul style="list-style-type: none"> • Body: SS 316 • Mechanism**: SS 303 • Bolting: SS 303 | <ul style="list-style-type: none"> • Body: SS 316L • Mechanism: SS 303 minimum |
| | <ul style="list-style-type: none"> • Industrial water • Brackish water • Active Cl < 1,00 mg/l • Total salts < 10,0 g/l <input type="checkbox"/> IND (Industry) | NGE-316 / Roll Seal <ul style="list-style-type: none"> • Body: SS 316 • Mechanism**: SS 316 • Bolting: SS 316 | <ul style="list-style-type: none"> • Body: SS 316L • Mechanism: SS 316 minimum |
| | <ul style="list-style-type: none"> • Brackish water • Sea water • Active Cl < 1,00 mg/l • Total salts < 40,0 g/l <input type="checkbox"/> OFS (Offshore, Marine) | NGE-316 / Roll Seal <ul style="list-style-type: none"> • Body: SS 316 • Mechanism**: Monel • Bolting: SS 316 | <ul style="list-style-type: none"> • Body: SS 316L • Mechanism: Monel minimum |
| | <ul style="list-style-type: none"> • Brackish water • Sea water • Active Cl < 0,30 mg/l • Total salts < 40,0 g/l <input type="checkbox"/> SWS (Sea Water Service) | NGE / GE / AE / EAE / TDV <ul style="list-style-type: none"> • Body: ductile iron* • Mechanism**: Monel • Bolting: SS 316 | <ul style="list-style-type: none"> • Body: marine grade bronze • Mechanism: Monel minimum |
| * Ductile iron: GGG 40 epoxy coated 250 µm min | | ** Mechanism: stem, stem nut and cover bearing. Standard seat and disc guide: SS 316 | |

| CLA-VAL STANDARDS FOR ELASTOMERS | | Active Cl | Total salts | Note |
|----------------------------------|---|-------------------------|-------------|------------------|
| U | <input type="checkbox"/> EPDM | < 0,3 mg/l | < 10g/l | Standard CLA-VAL |
| | <input type="checkbox"/> NBR | < 0,3 mg/l | < 40g/l | |
| | <input type="checkbox"/> Viton or Teflon protection | > 0,3 mg/l | < 40g/l | |
| | <input type="checkbox"/> EPDM, Viton or Teflon protection | Ozone (O ₃) | | |

| CLA-VAL STANDARDS FOR CALCAREOUS PROTECTION | | | |
|---|--------------------------|--|--|
| V | <input type="checkbox"/> | Neutral water (pH 7 - 9 / hardness: 15°F / active Cl < 0,1 mg/l) | STANDARD |
| | <input type="checkbox"/> | Aggressive water (CO ₂ attack, pH 6 - 7) | WWS minimum recommended |
| | <input type="checkbox"/> | Incrusting water (calcareous precipitation, hardness > 20°F) | Delrin (ΔP < 5 bar) or Teflon protection |