

DUOFIT D10

SINGLE BOLT STRAIGHT VERSION

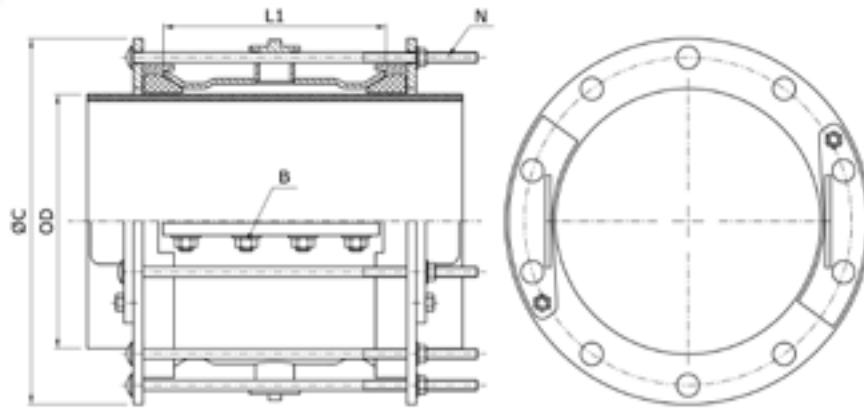

Straight version Duofit **D10** for repairs on damaged pipes (cracks, faulty weldings, corrosion, etc.) with no service cut off on pipes of any diameter. It can be also used for hot tapping techniques on pipes of any material and diameter with running fluids.

Other sizes or ranges on request

DN	Ø D		MOP (PN)	L1	Max. External Dimension Ø C	No. Flange Bolts N	No. Lateral Plates Bolts B	Weight
	Min.	Max.						
300	320	350	6-10-16	355	500	8	10	99
	350	370	6-10-16		520			
350	360	390	6-10-16		540	10		108
	400	420	6-10-16		580			
400	410	440	6-10-16		600	12		113
	450	465	6-10-16		620			
450	460	490	6-10-16		640	14		127
	500	520	6-10-16		680			
500	510	540	6-10-16		700	16		135
	550	565	6-10-16		720			
550	560	590	6-10-16		740	18		146
	600	620	6-10-16		783			
600	620	650	6-10-16		813	20		151
	645	675	6-10-16		838			
645	670	700	6-10-16		863	22		164
	695	725	6-10-16		888			
695	720	750	6-10-16		913	24		171
	750	780	6-10-16		943			
750	780	810	6-10-16		973	26		175
	835	865	6-10-16		1028			
835	860	890	6-10-16		1053	28		184
	895	925	6-10-16		1088			
895	925	955	6-10-16		1118	30		189
	955	985	6-10-16		1148			
955	985	1015	6-10-16		1178	32		200
	1000	1030	6-10-16		1193			
1000	1030	1060	6-10-16		1223	34		205
	1060	1090	6-10-16		1253			
1060	1080	1110	6-10-16	1273	36	214		
	1100	1130	6-10-16	1293				
1100	1130	1160	6-10-16	1323	38	222		
	1160	1190	6-10-16	1353				
1160	1185	1215	6-10-16	1378	40	227		
	1205	1235	6-10-16	1398				
1205	1235	1265	6-10-16	1428	42	232		
	1300	1330	6-10-16	1493				
1300	1335	1365	6-10-16	1528	44	237		
	1385	1415	6-10-16	1578				
1385	1410	1440	6-10-16	1603	46	241		
	1440	1470	6-10-16	1633				
1440	1510	1540	6-10-16	1703	48	246		
	1585	1615	6-10-16	1778				
1585	1610	1640	6-10-16	1803	50	250		
	1650	1680	6-10-16	1843				
1650	1825	1855	6-10-16	2018	52	255		
	1860	1890	6-10-16	2053				
1860	2020	2050	6-10-16	2213	54	260		
	2065	2095	6-10-16	2258				
2065					56	265		
					58	270		
					60	275		
					62	280		
					64	285		
					66	290		
					68	295		
					70	300		
					72	305		
					74	310		
					76	315		
					78	320		
					80	325		
					82	330		
					84	335		
					86	340		
					88	345		
					90	350		
					92	355		
					94	360		
					96	365		
					98	370		
					100	375		
					102	380		
					104	385		
					106	390		
					108	395		
					110	400		
					112	405		
					114	410		
					116	415		
					118	420		
					120	425		
					122	430		
					124	435		
					126	440		
					128	445		
					130	450		

This chart is for indicative purposes. Nova Siria srl can vary the indicated standards (tolerance range, dimensions and materials) according to specifications requested by Customers or to designing needs.