

WIDE RANGE COUPLINGS AND FLANGE ADAPTORS



VERSIONS	SME / SMFE	
	STANDARD	OPTIONS
NOMINAL SIZES	50 - 300	
PN	From PN 6 to PN 16	
MEDIUM	Potable and raw water	
BODY	Ductile iron	
COMPRESSION RINGS	Ductile iron	
SEALING GASKETS	EPDM rubber	
BOLTS	Steel with dacromet coating	Grade 304/316 stainless steel
COATING	Rilsan Nylon 11	
ANGULAR DEFLECTION	From DN50 to DN300 = +/-4° on each side with coupling ends*	

*average datum in the middle of the range

DESIGN FEATURES OF SMART JOINT COUPLINGS AND FLANGE ADAPTORS

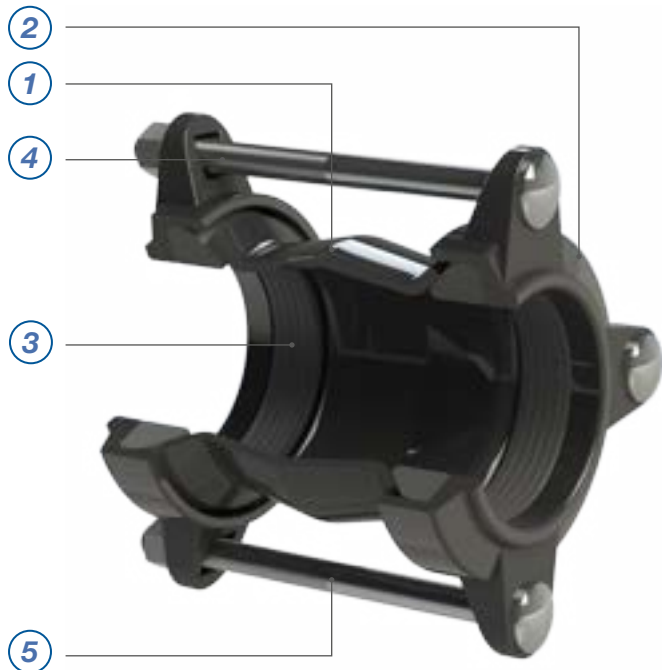

1 Central body

Ductile iron central body conveniently built in order to allow a perfect insertion of the gasket inside its dedicated conical seat.

2 Compression ring

Ductile iron compression followers which allow compression of the gasket onto the pipe surface upon tightening the bolts.

3 Gasket

Truncated-cone sealing gasket which can be perfectly inserted between the central body of the coupling and the circumference of the pipe. It allows a complete hydraulic seal and up to 26 mm tolerance range on the pipe OD.

4 Bolt holes

Round or square holes for the bolt insertion.

5 Compression bolts

The compression bolts allow the approaching of the compression flanges and the consequent compression of the gasket onto the pipe.

6 Connection flange (Flanged version)

Ductile iron flange.



The SMART series couplings represent the standard version of Nova Siria product range and provide a perfect and fast connection between pipes of any material with same or different outside diameters up to 327 mm. Versions: straight version, flanged version with multiple flange drillings and end restraint version (Pipe Locking System).